

AD ASTRA...



THE JOURNAL OF
THE ATARI MICROCOMPUTER NET
AMATEUR RADIO OPERATOR USERS' GROUP

AD ASTRA...

THE JOURNAL OF THE ATARI MICROCOMPUTER NETWORK

THE ATARI MICROCOMPUTER NET USERS' GROUP

NET COORDINATOR,

Jack McKirgan II, WD8BNB

4749 S.R. 207 N.E.

Washington C.H., Ohio 43160

(614) 869-3597

MAY-JUNE 1983

AD ASTRA... VOL. 2, # 1

The ATARI Microcomputer Net is a non-profit organization of amateur radio operators, short-wave listeners and ATARI Computer Enthusiasts who share a common interest- exchanging information on applications, programming and operation of the ATARI Microcomputer System. With these goals in mind, all persons are invited to join the net for the purpose of personal enlightenment and fraternalism. Amateur radio operators and short-wave listeners are especially encouraged to directly participate in the weekly on-the-air meetings.

"Ad Astra..." is the official journal of the ATARI Microcomputer Network and is made available to all registered members of the Net. "Ad Astra..." is an optional entity of the Net and there is no obligation to receive the journal. Members who wish to receive "Ad Astra..." are asked to help offset the cost of printing and postage by sending an annual donation of \$10.00 to Net headquarters at the address shown at the top of this page.

"Ad Astra..." is published six times per year by the ATARI Microcomputer Network and all articles contained herein are submitted and published with no promise, implied or expressed, of monetary compensation. Neither the Net, it's officials, members or authors may be held responsible for the validity or accuracy of the articles contained within the pages of this journal.

The ATARI Microcomputer Network Users' Group is not affiliated with ATARI, Inc., Warner Communications, or any of their subsidiary companies. The word "ATARI", alone or with a model number, or a model number alone such as 400, 800, 1200, 810, 410... etc. is a registered trademark of ATARI, Inc. The Fuji logo resembling  is also a registered trademark of ATARI, Inc. All use of the word "ATARI" or the Fuji logo on or between the pages of this journal are to be referenced as trademarks of ATARI, Inc.

EDITORIAL

My Dear Members, we have come a long way! As of the day of this writing, April 6, 1983, our membership is very close to the 500 mark! Chances are that we will meet or exceed that mark by the time that this, our FIRST ANNIVERSARY ISSUE, reaches you... certainly by the time that the Dayton Hamvention is over!

Our journal, "Ad Astra...", has received much praise from on high lately and while I can hold my head up for putting it together, it is you, the members, who make it possible with your wonderful participation! Yes, we do have some great talent among our ranks... but you don't have to be a systems analyst or have a BSEE to come up with a fantastic application program or a new piece of hardware or enhancement for your ATARI computer! Let us all in on your own personal developments... if we all do it, we will ALL become richer for it!

We are repeating one article from a previous issue in this anniversary tome. It is the very popular interface article by Don Page and Moury Sproul that originally appeared in Volume # 1, Issue 3 of "Ad Astra...". At the time that we first published it, we had about 200 members in the net... needless to say, there have been many who have requested photocopies of the original and I have tried to keep up with the demand. I just have a feeling that it would be a losing battle to continue! We are experiencing such rapid growth that I could make our local photocopy service a major industry in this little town if I were to continue! The alternative would be for me to buy a photocopier, but I'm afraid that my unemployment (Yes, friends, I'm in the steel industry!) won't allow me to budget such a purchase.

I had a joyful experience on the National Net on Easter, April 3rd. One of our CANADIAN firends, Gil, VE4AG, told us that he was taping the net for the benefit of his local ham radio club members! Gil and other Canadian members told me that the ATARI Computer System is one of, if not THE most popular system in Canada! That's very reassuring, indeed! By the way, our international membership is becoming quite diverse! Now we have members in England, Panama, South-West Africa, Iceland, West Germany.... even Jugoslavia!!! I would like to encourage our members in the European/African continental areas to form a net! A five to seven hour time difference, changes in propagation and local QRM will make it difficult, if not impossible for our continental friends to directly participate in our North-American nets. Anyone willing to undertake such an operation should contact me and I'll be glad to send a package of material to you to get started!

Our man in Panama, Mel, HP2XMK, tells me that during a meeting at the West Coast Computer faire with Earl Rice, head of ATARI's Users Group Support Team, that ATARI will have some VERY EXCITING news for us later in the year! Combined with the report from the Southern Nevada ATARI Computer Club, S.N.A.C.C, which says that they were told that ATARI's upper management has indeed been listening to the users' groups and will have some new UPPER END HARDWARE, leads us to believe that there may be some great new developments that will put the ATARI System well into the small-business market! Just conjecture on my part, but it is based on the enthusiasm of the participants of these meetings.

That's all for now, guys and gals, I hope you will enjoy this issue and I hope to meet you all at the Dayton Hamvention, April 29-30, May 1! -- 73 --
DE Jack, WD8BNG

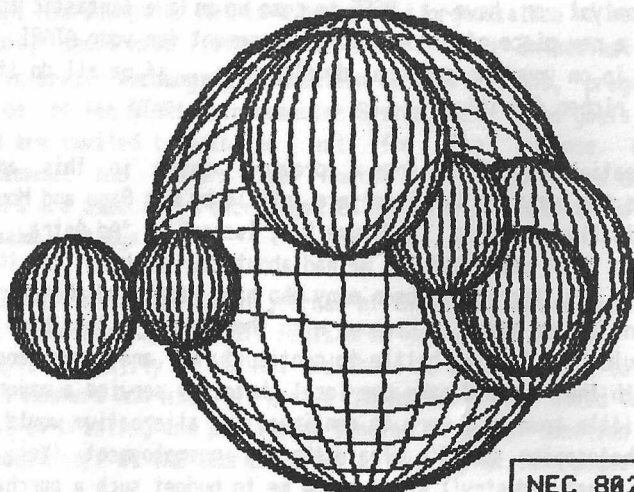

NEC 8023A-C ART
by Jack, WD8BNG

ERRATA! !

In Vol 1, Issue # 5 of "Ad Astra...", we printed an article on turning the BASIC (or other language) ROM on or off with a hardware switch. Many, many of the members have had great success with this modification. The drawing on page 15 of the journal is correct, but the text has an error in it- when counting the pins of the ROM's edge-card connector, you should commence the count from the **LEFT** of the connector to find pin 13. Actually, the article just says to find pin 13 when starting the count from the right, but when doing so, the first pin is # 15. The article is still correct, the wording is just a little nebulous. We hope that you were not misled. There were many sharp-eyed members who pointed out the possibility of confusion.
TNX Jack, WD8BNG

NET ORGANIZATION

Regional calling frequency: 7.235 Mhz (Call station or CQ ATARI)

National Net: 14.325 Mhz. at 1600Z, Sundays, NC/WD8BNG

Midwest Regional Net: 7.235 Mhz. at 1830Z, Sundays, NC/WD8BNG

Southeast Regional Net: 7.235 Mhz. at 1800Z, Sundays, NC/W4LDE

Southwest Regional Net: 7.230 Mhz. at 1800Z, Sundays, NC/KC5FW

Pacific NW Regional Net: 7.230 Mhz. at 1800Z, Sundays, NC/KC7DG

East Coast Regional Net: 3.960 Mhz. at 8 pm EST, Wednesdays, NC/KA1IRA

West Coast Regional Net: 7.235 Mhz. at 11 am PST, Sundays, NC/WA6TUB

International Net: 21.400 Mhz. at 2330Z, Alternate Thursdays, NC/WD8BNG

Dayton, Ohio Local Net: Open channel daily on 146.445 Mhz., Simplex

Chicago, IL Local Net: Open channel daily on 147.570 Mhz., Simplex

Central Kentucky Local Net: 145.85 (TX 600Khz down) repeater, 8 pm EST, Wednesdays, NC/WD4HPL

Additional nets will be formed as regional/local net control stations volunteer their time. If you would like to start a regional/local net in your area, contact WD8BNG for a Net Coordinator's packet.

New Net!

Don Page, WD4HPL, has started a new local net in Central Kentucky on the 145.85 (TX -600) repeater! Net attendance has been good and all are welcome to join in. Don reports that the repeater gives excellent coverage to all of central Kentucky and beyond! If you live anywhere near this area, please try to make it! Don is very knowledgeable about the ATARI Computer System and he would be glad to hear from you.

If you should listen to a regional net frequency and not hear the net control call up the net, it is possible that the NC got tied up... don't be afraid of calling up the net yourself! I'm sure that you would be well rewarded!

RTTY/CW/ASCII INTERFACE

by Don Page, W04HPL and
Maury Sproul, W5UGQ

Editor's note: Because of the high demand for reprints of this article, we felt that it would be beneficial to present it once again. Combined with the enhancements and rig-specific modifications that we have presented in recent issues of "Ad Astra...", this is one of the most versatile and valuable projects for the ATARI/ham.

This article describes a computer interface for receiving and transmitting RTTY/ASCII/CW. The interface was designed to be used with the ATARI Computer System using the Kantronics' "HAMSOFT" firmware, however it can also be used with other software packages with only care taken to observe the correct I/O connections.

CIRCUIT DESCRIPTION

The RTTY receive block is comprised of IC1, IC3A, IC3B and IC6. IC1A is an op amp operating as a limiter. That is, for an input signal of varying amplitude, the output of the limiter will be of constant amplitude. In this case, the output will be a clipped sine wave or a square wave, depending on the input level. The output of the limiter is fed to IC1B which is configured as an active filter. The active filter is designed to pass the standard RTTY audio tones of 2125 and 2295 Hz. The output of the active filter drives the tuning meter and IC6, the RTTY demodulator. IC6 is an EXAR 2211 PLL device. The component values associated with the 2211 are the values recommended by EXAR for the demodulation of the AFSK data at speeds up to 300 baud. For further details on the 2211, see the application notes available from EXAR.

The demodulated data from the 2211 is fed to the input of IC3B, an open collector NOR gate. The output of IC3B feeds IC3A. The demodulated data at TTL level can be selected at the output of either IC3B or IC3A. The normal output (2125 Hz.= logic "1") is selected at the output of IC3A. The reversed output (2125 Hz.= logic "0") is selected at the output of IC3B. A light emitting diode (LED) is connected to the data output line to provide a visual indication as the data is received. The LED will be off for a logic "1" (MARK) signal and on for a logic "0" (SPACE) signal. The data output to the computer is a TTL signal with the normal or reverse sense selected by switch S1A.

The RTTY transmit block is comprised of IC7, IC5, and IC3D. IC7 is an EXAR 2206 function generator that will provide a sine wave output. The output frequency is determined by a capacitor/resistor

combination. The 2206 has the additional capability of selection of a second output frequency by the logic level that is applied to the control line. With this capability, a simple AFSK generator can be built. The application of a logic "1" to the control pin will produce a 2125 Hz. output and a logic "0" will produce a 2295 Hz. output. The logic to select the output frequency of the 2206 is dictated by a peculiarity of the Kantronics firmware. The Kantronics program provides for the capability for CW identification in the RTTY/ASCII mode. However, the identification is by CW keying rather than the usual AFSK. This can be resolved by the use of a NOR gate to produce an AFSK output from the 2206 for either CW or RTTY. IC3D inverts the signal applied to the 2206 through switch S1B to produce normal (MARK= 2125 Hz.) or reversed (MARK=2295 Hz.) AFSK. The AFSK output of the 2206 is fed to the microphone input of the transmitter.

The CW receive block is comprised of IC2, IC4, and IC5B. The function of IC2 is similar to that of IC1, that is a limiter followed by an active filter. In this case, the active filter is designed to pass approximately 650 Hz. The output of the active filter is integrated by a capacitor/resistor combination which is fed to IC4A, a Schmitt-trigger. The output of IC4A is further integrated and fed to IC4B, also a Schmitt-trigger. The output of IC4B is fed to IC5B which inverts the signal and provides a TTL-level signal to the ATARI. A LED is connected to the output of IC5B to give a visual indication of the received CW. The combination of the active filter and the Schmitt-triggers provide a very narrow band-pass and excellent recovered CW. The circuit has been used for the reception of computer-generated CW up to 90 WPM which is near the limit of the Kantronics program.

The control block of the interface consists of Q1, IC3A, and Q2. Q1 permits computer control of the PTT circuit of the transmitter. IC3A inverts the PTT signal from the computer and provides the base drive to Q1. Q2 is used to interface the ATARI to the CW keying of the transmitter. (A Kerwood TS-520 was used in the development of this circuit). Since the keying of the TS-520 requires the keying of an approximately -60 volt line, the emitter biased configuration was used for Q2 to provide reliable keying. On-the-air tests have been conducted with excellent results up to 90 WPM.

The remaining element of the control block is the 7805 regulator which provides the regulated +5 volts for IC3, IC4 and IC5.

ALIGNMENT

The alignment of the interface requires the use of a frequency counter and either an audio frequency generator or a receiver.

RTTY RECEIVE

1. Turn on the power to the interface.
2. Connect an audio source to the input of the RTTY receive block.
3. Adjust the audio source to 2125 Hz.
4. Adjust R1 for maximum meter reading.
5. Place S1 in the "NORMAL" position.
6. Observe the RTTY data LED.
 - a. If the LED is lighted, adjust R3 until the LED goes out.
 - b. If the LED is out, adjust R3 until the LED is lit then re-adjust until the LED goes out.
7. Adjust the audio source to 2295 Hz.
8. The RTTY data LED should now be lighted. If not, adjust R3 until the LED lights.
9. Repeat steps 3,6,7 and 8 until the LED is out for 2125 Hz. and lighted for 2295 Hz.
10. Connect the interface to a receiver and tune in a strong RTTY signal in one of the amateur bands that is free of any interference. Use the lower sideband position. Adjust the receiver tuning for maximum indication of the tuning meter. The RTTY data LED should be flashing on in step with the keying of the received signal. If not, carefully adjust the tuning of the receiver until the LED flashes in step with the signal. Adjust R1 for maximum indication. Tuning of RTTY signals should now coincide with the point where the LED flashes in step with the signal. The LED should be off when no data is being sent, that is, a steady tone.
11. At this point, it is assumed that the computer and a RTTY receiving program are available.
12. Connect the output of the interface, CW/RTTY receive keying to the computer input. (DB9 or DE9S connector to joystick port 1).
13. Initialize the RTTY program to receive baudot at 45 baud (60 WPM).
14. Tune in a RTTY signal. The majority of the RTTY signals in the amateur bands are 45 baud baudot. Observe the receive copy of the computer. If the received RTTY signal is strong and free of interference, tuned for maximum meter indication, the RTTY LED is flashing on in step with the signal's frequency shift, then the computer should be displaying understandable text. If not, make a small adjustment of R3 in either direction and note if any improvement in the text. This will set the 2211 to the correct operating point. If no improvement in the text is noted then:
 - a. The signal may not be 45 baud or on the proper sideband- try another signal.
 - b. If still no improvement, go to step 2 and start over.

ON ICs 3, 4 & 5
 Pin 7-- Ground
 Pin 14-- Plus 5 Volt Buss

- IC1, IC2 - 1558
- IC3 - 7493
- IC4 - 7413
- IC5 - 2110
- IC6 - 7410 (LS24)
- IC7 - 2304 (LS24)

All capacitors less than 1uf are nylon or polystyrene, unless noted.
 All resistors 1/4 watt.

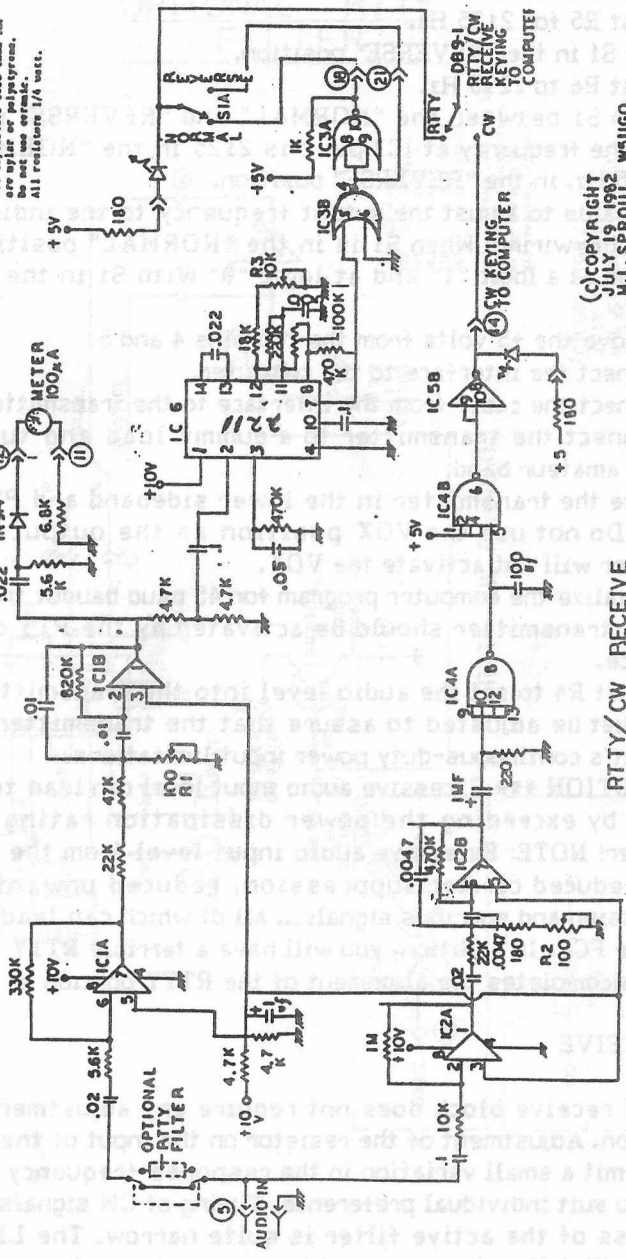

(COPYRIGHT
 JULY 19 1982
 M. L. SPROUL WSUGQ
 R. F. PAGE WD4VBT
 REVISED 8/25/82)

RTTY / CW RECEIVE

089-8

RTTY TRANSMIT

1. Disconnect the interface from the computer.
2. Apply +5 volts to IC5, pins 4 and 5
3. Place S1 in the "NORMAL" position.
4. Connect a frequency counter to IC7, pin 2
5. Adjust R4 to mid-range.
6. Adjust R5 for 2125 Hz.
7. Place S1 in the "REVERSE" position.
8. Adjust R6 to 2295 Hz.
9. Switch S1 between the "NORMAL" and "REVERSE" positions and assure the frequency at IC7 pin 2 is 2125 in the "NORMAL" position and 2295 Hz. in the "REVERSE" position.
10. If unable to adjust the output frequency to the indicated values, recheck the wiring. When S1 is in the "NORMAL" position, IC7 pin 9 should be at a logic "1" and at logic "0" with S1 in the "REVERSED" position.
11. Remove the +5 volts from the IC5 pins 4 and 5.
12. Connect the interface to the computer.
13. Connect the cable from the interface to the transmitter.
14. Connect the transmitter to a dummy load and tune up on the desired amateur band.
15. Place the transmitter in the lower sideband and PTT positions.
NOTE: Do not use the VOX position as the output of the AFSK generator will not activate the VOX.
16. Initialize the computer program for 45 baud baudot transmit.
17. The transmitter should be activated by the PTT circuit in the interface.
18. Adjust R4 to set the audio level into the transmitter. The audio level must be adjusted to assure that the transmitter is operating within it's continuous-duty power input limitations.
*** CAUTION *** Excessive audio input level can lead to transmitter failure by exceeding the power dissipation rating of the final amplifier! NOTE: Excessive audio input level from the interface can cause reduced carrier suppression, reduced unwanted sideband suppression and spurious signals... all of which can lead to a citation from the FCC. In addition, you will have a terrible RTTY signal!
19. This completes the alignment of the RTTY portion of the interface.

CW RECEIVE

The CW receive block does not require any adjustment for proper operation. Adjustment of the resistor on the input of the active filter will permit a small variation in the response frequency of the active filter to suit individual preference. Tuning of CW signals is critical as bandpass of the active filter is quite narrow. The LED in the CW output will follow the keying of the received signal.

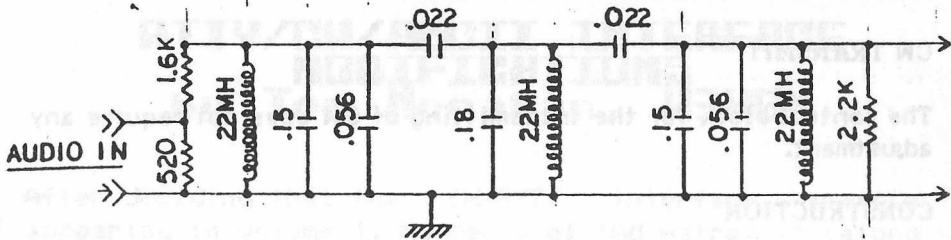

OPTIONAL RTTY FILTER

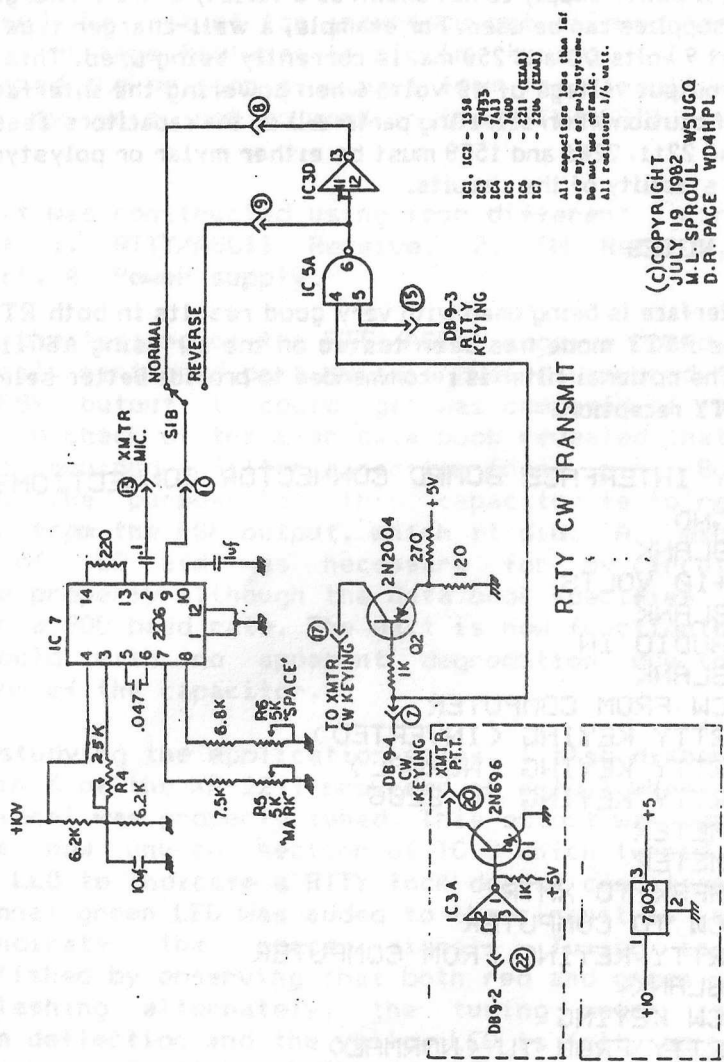

- IC1, IC2 - 1558
 - IC3 - 74135
 - IC4 - 7460
 - IC5 - 2211 (EJAN)
 - IC6 - 2206 (EJAN)
 - IC7 - 7410
- All capacitors less than 1uf are electrolytic.
Do not use ceramic.
All resistors 1/4 watt.

(C) COPYRIGHT
JULY 19 1982 WSUGQ
M.L. SPROUL
D.R. PAGE WD4HPL

RTTY CW TRANSMIT

CW TRANSMIT

The control block for the transmitting of CW does not require any adjustment.

CONSTRUCTION

Construction of the interface is not critical. The interface can be constructed on perf-board using wire-wrap or point-to-point wire and solder. A power supply is not shown as a variety of wall-charger type power supplies can be used. For example, a wall-charger type supply rated at 9 volts DC and 250 ma. is currently being used. This supply has an output voltage of 10 volts when powering the interface. One word of caution when selecting parts: All of the capacitors associated with the 2211, 2206 and 1558 must be either mylar or polystyrene to assure stability of the circuits.

FINAL NOTES

The interface is being used with very good results in both RTTY and CW. The RTTY mode has been tested on the air using ASCII at 300 baud. The optional filter is recommended to provide better selectivity for RTTY reception.

RTTY INTERFACE BOARD CONNECTOR CONNECTIONS

- 1 GND
- 2 BLANK
- 3 +10 VOLTS
- 4 BLANK
- 5 AUDIO IN
- 6 BLANK
- 7 CW FROM COMPUTER
- 8 RTTY KEYING (INVERTED)
- 9 RTTY KEYING (NORMAL)
- 10 RTTY KEYING TO 2206
- 11 METER
- 12 METER
- 13 AFSK TO XMTR
- 14 CW TO COMPUTER
- 15 RTTY KEYING FROM COMPUTER
- 16 BLANK
- 17 CW KEYING
- 18 RTTY FROM TU (NORMAL)
- 19 LED
- 20 RTTY TO XMTR
- 21 RTTY FROM TU (INVERTED)
- 22 PTT FROM COMPUTER

RTTY/CW/ASCII INTERFACE MODIFICATIONS by Tom Monahan, W3WGM

After deciding that the CW/RTTY interface article appearing in Volume 1, Number 3 of "Ad Astra..." (along with the corrected schematic) was just the unit I wanted by offering low cost and simplicity, I next decided on a construction method that slightly increased the cost of the interface but allowed for the addition of some features to aid in tuning. I also discovered the omission of a part from the circuit which caused my unit not to work in the RTTY/ASCII receive mode.

The unit was constructed using four different circuit boards: 1. RTTY/ASCII Receive, 2. CW Receive, 3. Transmit, 4. Power supply.

During the testing of the RTTY/ASCII receive board, the previously mentioned part omission was discovered then only FSK output I could get was composed of random pulses. A check of the Exar data book revealed that the XR-2211 required a filter capacitor from pin 8 to ground. The purpose of this capacitor is to remove chatter from the FSK output, which it did. A minimum value of .02 ufd was necessary for my circuit to operate properly although the data book specifies .005 ufd for a 300 baud rate. The unit is now functioning as it should with no apparent degradation due to the addition of the capacitor.

While studying the application notes, I also discovered that pin 6 of the XR-2211 provided an output when the RTTY signal was properly tuned. This output was applied to the now unused section of IC 3 which turned on a yellow LED to indicate a RTTY lock detect condition. An additional green LED was added to the circuit as shown to indicate the space signal. Tuning is now accomplished by observing that both red and green LEDs are flashing alternately, the tuning meter is at maximum deflection and the yellow LED is fully on with no flickering. Although the addition of two more LEDs might seem like overkill, I have found that they do add to the ease of tuning with only a slight increase in

the cost of construction, not to mention that three LEDs add much more to the aesthetics of the interface than just one.

Implementing the above will require an additional 7433 IC as section "C" of IC 3 is now used for the lock detection LED. Additional LEDs and resistors will also be required.

The interface has proven to be an excellent performer under moderate QRM and USB conditions without the aid of a RTTY filter while receiving on a TEN TEC 540 transceiver.

73, DE Tom, W3WCM

Editor's note: Due to the giant increase in our membership and the need for reprints of this interface article, we are reprinting the complete article (with corrections) in this issue. As noted in previous issues of "Ad Astra...", there may be some changes to the circuit for the keying circuits of some transceivers.



**ATARI[®] COMPUTER
ENTHUSIASTS**

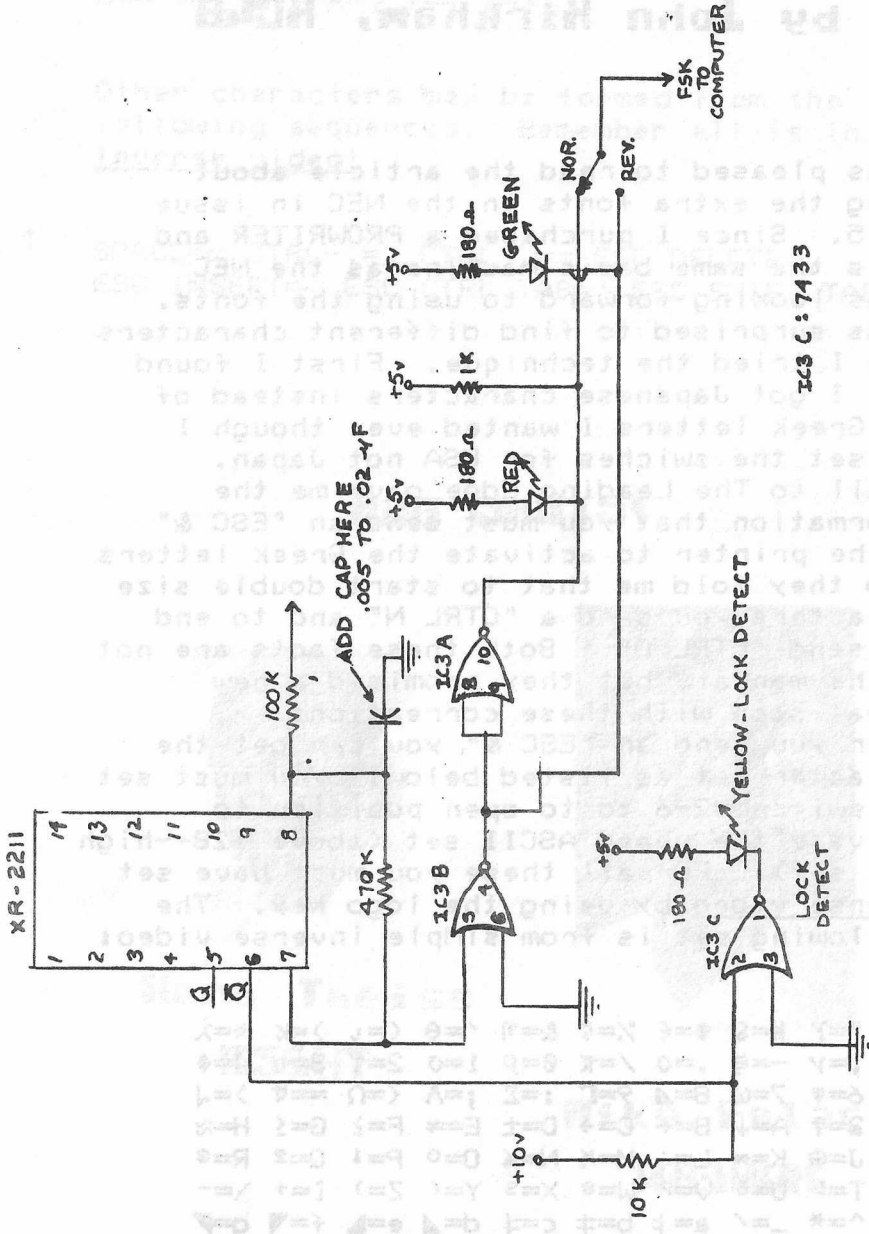

IC3 C : 7433

MODIFICATION FOR RITTY/ASCII/CW INTERFACE

PROWRITER CHARACTERS by John Kirkham, KC4B

I was pleased to read the article about using the extra fonts in the NEC in issue No. 5. Since I purchased a PROWRITER and it is the same basic machine as the NEC I was looking forward to using the fonts. I was surprised to find different characters when I tried the technique. First I found that I got Japanese characters instead of the Greek letters I wanted even though I had set the switches for USA not Japan. A call to The Leading Edge gave me the information that you must send an "ESC &" to the printer to activate the Greek letters. Also they told me that to start double size characters you send a "CTRL N" and to end you send "CTRL O". Both these facts are not in the manual, but they promised a new manual soon with these corrections. After you send an "ESC &" you can get the character set as listed below. You must set DIP switch #2-6 to to open position to activate the upper ASCII set (above 128--high bit set). For all these you must have set inverse video by using the logo key. The following set is from simple inverse video:

```

!=ß  " =γ  # =δ  $ =€  % =ζ  & =η  ' =θ  ( =ι  ) =κ  * =λ
+=μ  , =ν  - =ξ  . =ο  / =π  0 =ρ  1 =σ  2 =τ  3 =υ  4 =ϕ
5 =x  6 =ψ  7 =ω  8 =Δ  9 =Γ  : =Σ  ; =Λ  < =Ω  ==ϑ  > =J
? =°  @ =↑  A =↓  B =←  C =→  D =±  E =*  F =≥  G =≤  H =≈
I =·  J =⊕  K =∞  L =∴  M =½  N =¼  O =ο  P =1  Q =2  R =³
S =4  T =5  U =6  V =7  W =8  X =9  Y =(  Z =)  [+ =+  \ =-
] =·  ^ =*  _ =/  a =†  b =‡  c =‡  d =▲  e =▴  f =▼  g =▽
h =♣  i =♥  j =♦  k =♠  l =●  m =ο  n =/  o =\  p =X  q =...
r =!  s =+  t =-  u =|  v =|  w =+

```



The following are with the CTRL key as well as inverse video:

A= _ B= _ C= _ D= _ E= _ F= _ G= _ H= | I= | J= |
K= | L= | M= | N= | O= + P= + Q= + R= + S= + T= +
U= _ V= | W= | X= r Y= r Z= L

Other characters may be formed from the following sequences. Remember all is in inverse video!

SPACE=α CTRL-, =_ CTRL-., = ESC DELETE= /
ESC INSERT= \ ESC CTRL TAB= \ ESC SHIFT TAB= /

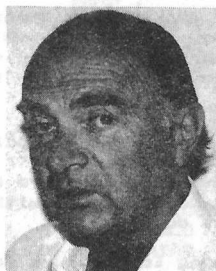
MUG SHOTS!



Herb Theiss

253HT

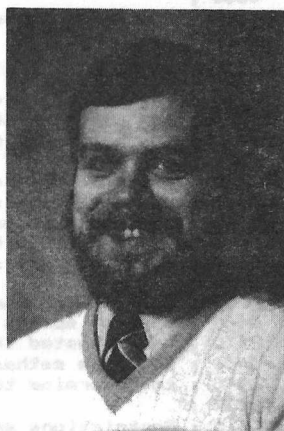

Mike Felack

W43WDM

Let's see YOUR photo!

TTY PRINTER DRIVER

by Stace, KEOF

TTY PRINTER DRIVER - DOS VERSION SYSTEM DOCUMENTATION

```
0000      0100      .PAGE "SYSTEM DOCUMENTATION"
          0110 ; NOTICE:
          0120 ; This program is being donated as
          0130 ; free, public domain software. I am giving all parties
          0140 ; unlimited right to use, modify, copy, distribute
          0150 ; this program. I am specifically withholding the
          0160 ; rights to sell for profit this program or any
          0170 ; direct derivative thereof.
          0180 ;
          0190 ; March 1983
          0200 ; Hadley V. Stacey - KEOF
          0210 ;
          0220 ; Its function is to replace the standard Atari
          0230 ; printer driver with one which supports 110 baud
          0240 ; ascii printers driven thru joystick port 1.
          0250 ;
          0260 ; Because of the size, and for reasons of compatibility with
          0270 ; other software, most users will want two versions,
          0280 ; - one for running without a cartridge
          0290 ; - and one for use with a cartridge present.
          0300 ;
          0310 ; It can be assembled using the Atari Assembler/Editor.
          0320 ;
          0330 ; After you boot DOS, load the appropriate version using
          0340 ; the "L" option on the DOS menu. It will move
          0350 ; the display area in high memory down to make sufficient
          0360 ; room, then link itself to the device handler table
          0370 ; as device P: (printer).
          0380 ;
          0390 ; After it has been loaded it will honor all printer requests
          0400 ; just like the standard print driver.;
          0410 ; It does have one advantage over the standard driver,
          0420 ; you can drive the TTY driver concurrently with a modem,
          0430 ; something Atari won't let you do.
          0440 ;
          0450 ; The listing contains the timing loop values for
          0460 ; several speeds other than 110 baud. I have
          0470 ; never tested them but they were derived using
          0480 ; the same mathematical analysis which were used
          0490 ; to determine the values for 110 baud.
          0500 ;
          0510 ; Restrictions and Limitations
          0520 ; 1. You must reload the driver if you
          0530 ; warstart (eg. hit System Reset)
          0540 ; 2. The timing loop values are sensitive to
          0550 ; vertical blank interrupt processing time,
          0560 ; and the characteristics of the display list.
          0570 ; If you build a different display list, or
          0580 ; extend the vertical blank handler it may
          0590 ; may be necessary to adjust the timing values.
          0600 ; 3. It will not work with the program text editor
```

```

0610 ; because of a conflict in memory addresses.
0620 ; 4. I have had persistent problems using it as
0630 ; an AUTORUN.SYS file. I don't know what
0640 ; the problem is, and have not been too interested
0650 ; in trying to diagnose it.
0660 ;
0670 ; I hope it is useful to you. It gave me a way
0680 ; to use a free printer. Model 33's and 35's are
0690 ; selling for $25 to $100 in the Denver area, cheap
0700 ; but slow.
0710 ;
0720 ; The code could be adapted to drive a BAUDOT
0730 ; printer if you are so inclined, just have to
0740 ; change the serialization routine to translate to 5 level,
0750 ; and handle letters/figs generation.
0760 ;
0770 ; 73 - KEOF (stace)

```

NOTE: Use Port 1, Pin # 1 to switch current loop!

**TTY PRINTER DRIVER - DOS VERSION
SYSTEM VARIABLES**

```

0000      0780      .PAGE "SYSTEM VARIABLES"
          0790 ;
          0800 ; SET PTRORG TO:
          0810 ;      $9E00 IF CARTRIDGE USED
          0820 ;      $BE00 IF NO CARTRIDGE
09E00    0830 PTRORG = $9E00
          0840 ;
          0850 ; CIO COMMAND EQUATES
0003    0860 OPEN  = $03
000B    0870 PUTCHR = $0B
000C    0880 CLOSE = $0C
          0890 ;
          0900 ; CIO MODE EQUATES
0004    0910 OPNIN  = $04
000B    0920 OPNPF = $0B
          0930 ;
          0940 ; SYSTEM PAGE 0 VARIABLES
0011    0950 BRKKEY = $11
006A    0960 RAMTOP = $6A
          0970 ;
          0980 ; OTHER SYSTEM VARIABLES
022A    0990 CDTMF3 = $022A
02E0    1000 RUNADR = $02E0
02E2    1010 INTADR = $02E2
02E4    1020 RAMSIZ = $02E4
02E5    1030 MEMTOP = $02E5
02E7    1040 MEMLO  = $02E7
031A    1050 HATAB  = $031A
          1060 ;
          1070 ; IOCB FIELDS
0342    1080 ICCOM  = $0342
0344    1090 ICBAL  = $0344
0345    1100 ICBAH  = $0345
0348    1110 ICBLL  = $0348
0349    1120 ICBLLH = $0349
034A    1130 ICAX1  = $034A
034B    1140 ICAX2  = $034B
          1150 ;
          1160 ; DCB EQUATES
0301    1170 DUNIT  = $0301
0302    1180 DCOMND  = $0302
0304    1190 DBUF   = $0304
030A    1200 DSECT  = $030A
          1210 ;
          1220 ; HARDWARE REGISTERS
D010    1230 TRIB0  = $D010
D011    1240 TRIB1  = $D011
D01D    1250 BRACTL = $D01D
D300    1260 PORTA  = $D300
D301    1270 PORTB  = $D301
D302    1280 PACTL  = $D302

```

TTY PRINTER DRIVER - DOS VERSION
SYSTEM VARIABLES

```
D303      1290 PBCTL = $D303
D40E      1300 NMIIEN = $D40E
          1310 ;
          1320 ; SYSTEM ENTRY POINTS
07E0      1330 DOSINT = $07E0
E45C      1340 SETVBV = $E45C
E456      1350 CIOV = $E456
E453      1360 DSKINV = $E453
```

TTY PRINTER DRIVER - DOS VERSION
MOVE DISPLAY AREA

```
0000      1370      .PAGE "MOVE DISPLAY AREA"
0000      1380      $= $B000
8000      1390 PPRINT = $
8000 A99D  1400      LDA #PTROR8/256-1
8002 B56A  1410      STA RAMTOP
8004 BDE402 1420      STA RAMBIZ
8007 BDE602 1430      STA MEMTOP+1
800A CEE602 1440      DEC MEMTOP+1
800D A9FF  1450      LDA #$FF
800F BDE502 1460      STA MEMTOP
8012 20F6F3 1470      JBR $F3F6
8015 60 1480      RTS
8016 1490      $= INTADR
02E2 00B0 1500      .WORD PPRINT
```

TTY PRINTER DRIVER - DOS VERSION
SYSTEM DATA BASE

```
02E4      1510      .PAGE "SYSTEM DATA BASE"
          1520 ;
02E4      1530      $= PTROR8
          1540 ; LOCAL DATA BASE
009B      1550 NL = 155
000D      1560 CR = 13
000A      1570 LF = 10
0018      1580 BSP = 24
000C      1590 FF = 12
0007      1600 BEL = 7
0009      1610 HT = 9
0001      1620 TMARK = 1
0000      1630 TSPACE = 0
9E00 01 1640 LPCOL .BYTE 1
9E01 01 1650 LPLIN .BYTE 1
9E02 4F 1660 RMARG .BYTE 73
9E03 00 1670 WTCT .BYTE 0
9E04 00 1680 XCT .BYTE 0
9E05 00 1690 YCT .BYTE 0
9E06 00 1700 SERCHR .BYTE 0
9E07 00 1710 SPCCT .BYTE 0
9E08 00 1720 NXTTB .BYTE 0
9E09 00 1730 BITARY .BYTE TSPACE
9E0A 00 1740 .BYTE 0,0,0,0,0,0,0,0
9E0B 00
9E0C 00
9E0D 00
9E0E 00
9E0F 00
9E10 00
9E11 00
9E12 01 1750 .BYTE TMARK, TMARK
9E13 01
```

TTY PRINTER DRIVER - DOS VERSION
 BAUD RATE/DELAY LOOP TERM TABLE

```

9E14      1760      .PAGE "BAUD RATE/DELAY LOOP TERM TABLE"
1770 ;
1780 ; -----
1790 ; BAUD RATE VS DELAY LOOP TERM
1800 ; TABLE. EACH ENTRY IS X,Y PAIR
1810 ;
1820 ; DELAY TIME IN CYCLES IS:
1830 ; DT=27+XVAL*(19+YVAL*9)
1840 ; CYCLE TIME IS .876562 USEC
1850 ;
9E14      1860 XVAL  = 8
9E15      1870 YVAL  = XVAL+1
9E16      1880 BITCT = YVAL+1
9E14 OE   1890      .BYTE 14,77,11 ; 0  110
9E15 4D
9E16 0B
  
```

```

1900 ; .BYTE 32,11,10 ; 1  300
1910 ; .BYTE 2,102,10 ; 2  600
1920 ; .BYTE 06,15,10 ; 3 1200
1930 ; .BYTE 11,04,10 ; 4  1800
1940 ; .BYTE 07,05,10 ; 5  2400
1950 ; .BYTE 03,11,10 ; 6  3000
1960 ; .BYTE 02,14,10 ; 7  3600
1970 ; .BYTE 01,25,10 ; 8  4200
1980 ; .BYTE 01,21,10 ; 9  4800
1990 ; .BYTE 02,05,10 ;10 7200
2000 ; .BYTE 02,03,10 ;11 9600
2010 ; .BYTE 01,04,10 ;12 19200
2020 ; -----
2030 ;
  
```

TTY PRINTER DRIVER - DOS VERSION
 INITIALIZATION

```

9E17      2040      .PAGE "INITIALIZATION"
2050 ;
9E17      2060 RSTART = 8
9E17 A938  2070      LDA  ##3B
9E19 8D02D3 2080      STA  PACTL
9E1C A9FF  2090      LDA  ##FF
9E1E 8D00D3 2100      STA  PORTA
9E21 A93C  2110      LDA  ##3C
9E23 8D02D3 2120      STA  PACTL
9E26 A900  2130      LDA  ##00
9E28 8D1DD0 2140      STA  BRCTL
9E2B A9FF  2150      LDA  ##FF
9E2D 8D00D3 2160      STA  PORTA
9E30 A93B  2170      LDA  #PRVCTR&#00FF
9E32 8D1B03 2180      STA  HATAB+1
9E35 A99E  2190      LDA  #PRVCTR/256
9E37 8D1C03 2200      STA  HATAB+2
9E3A 60    2210      RTS
2220 ;
9E3B      2230 PRVCTR = 8
9E3B 469E  2240      .WORD PTROPN-1
9E3D 4B9E  2250      .WORD PTRCLS-1
9E3F 659F  2260      .WORD PTRSTB-1
9E41 4D9E  2270      .WORD PTRPTB-1
9E43 659F  2280      .WORD PTRSTA-1
9E45 659F  2290      .WORD PTRSPC-1
  
```

TTY PRINTER DRIVER - DOS VERSION
 DEVICE HANDLER.

```

9E47      2300      .PAGE "DEVICE HANDLER"
          2310      ;
          2320      ; OPEN HANDLER
9E47      2330      PTROPN      = *
9E47 A901   2340      LDA      #01
9E49 8D019E 2350      STA      LPLIN
          2360      ;
          2370      ; CLOSE HANDLER
9E4C      2380      PTRCLS      = *
9E4C A90D   2390      LDA      #CR
          2400      ;
          2410      ; PUT BYTE HANDLER FOR MODEL 33/35 TELETYPE
9E4E      2420      PTRPTB      = *
9E4E AB     2430      TAY
9E4F BA     2440      TXA
9E50 4B     2450      PHA
9E51 9B     2460      TYA
9E52 4B     2470      PHA
9E53 AD039E 2480      LDA      WTCT
9E56 F013   2490      BEQ      TTY01
9E58 AB     2500      TAY
9E59 A903   2510      LDA      #3      ; TIMER 3
9E5B A200   2520      LDX      #0
9E5D 8E039E 2530      STX      WTCT
9E60 8D2A02 2540      STA      CDTMF3
9E63 205CE4 2550      JSR      SETVVB
9E66      2560      TTY00      = *
9E66 AC2A02 2570      LDY      CDTMF3      ; WAIT FOR PRV CHAR TO COMPLETE
9E69 D0FB   2580      BNE      TTY00
9E6B      2590      TTY01      = *
9E6B 6B     2600      PLA
9E6C A411   2610      LDY      BRKKEY
9E6E D005   2620      BNE      TTY02
9E70 A0B0   2630      LDY      #9B0
9E72 4C649F 2640      JMP      TTYEXT
9E75      2650      TTY02      = *
          2660      ;
9E75      2670      CHKNL      = *
9E75 C99B   2680      CMP      #NL
9E77 D00D   2690      BNE      CHKCR
9E79 A90A   2700      LDA      #LF
9E7B 204E9E 2710      JSR      PTRPTB
9E7E A90D   2720      LDA      #CR
9E80 204E9E 2730      JSR      PTRPTB
9E83 4C629F 2740      JMP      TTYXT
          2750      ;
9E86      2760      CHKCR      = *
9E86 C90D   2770      CMP      #CR
9E8B D01B   2780      BNE      CHKLF
9E8A 20679F 2790      JSR      SEROUT
9E8D AD009E 2800      LDA      LPCOL
    
```

TTY PRINTER DRIVER - DOS VERSION
 DEVICE HANDLER

```

9E90 4A     2810      LSR      A
9E91 4A     2820      LSR      A
9E92 8D039E 2830      STA      WTCT
9E95 A901   2840      LDA      #01
9E97 8D009E 2850      STA      LPCOL
9E9A A900   2860      LDA      #0
9E9C 8D079E 2870      STA      SPCCT
9E9F 4C629F 2880      JMP      TTYXT
          2890      ;
9EA2      2900      CHKLF      = *
9EA2 C90A   2910      CMP      #LF
9EA4 D01A   2920      BNE      CHKHT
9EA6 20679F 2930      JSR      SEROUT
9EA9 A902   2940      LDA      #02
9EAB 8D039E 2950      STA      WTCT
9EAE EE019E 2960      INC      LPLIN
    
```

```

9EB1 AD019E 2970 LDA LPLIN
9EB4 C943 2980 CMP #67
9EB6 D005 2990 BNE CHKLF1
9EB8 A901 3000 LDA #01
9EBA 8D019E 3010 STA LPLIN
9EBD 3020 CHKLF1 = *
9EBD 4C629F 3030 JMP TTYXT
          3040 ;
9ECO 3050 CHKHT = *
9ECO C909 3060 CMP #HT
9EC2 D023 3070 BNE CHKFF
9EC4 D8 3080 CLD
9EC5 18 3090 CLC
9EC6 A908 3100 LDA #08
9EC8 6D009E 3110 ADC LPCOL
9ECB 29F8 3120 AND #*F8
9ECD CD029E 3130 CMP RMARG
9ED0 9005 3140 BCC CHKHT1
9ED2 A99B 3150 LDA #NL
9ED4 4C759E 3160 JMP CHKNL
9ED7 3170 CHKHT1 = *
9ED7 8D009E 3180 STA LPCOL
9EDA A909 3190 LDA #HT
9EDC 20679F 3200 JSR SEROUT
9EDF A91E 3210 LDA #30
9EE1 8D039E 3220 STA WTCT
9EE4 4C629F 3230 JMP TTYXT
          3240 ;
9EE7 3250 CHKFF = *
9EE7 C90C 3260 CMP #FF
9EE9 D01B 3270 BNE CHKBEL
9EEB AC009E 3280 LDY LPCOL
9EEE C001 3290 CPY #01
9EF0 F00A 3300 BEQ CHKFO2
9EF2 A90D 3310 LDA #CR
9EF4 204E9E 3320 JSR PTRPTB

```

TTY PRINTER DRIVER - DOS VERSION
DEVICE HANDLER

```

9EF7 3330 CHKFO1 = *
9EF7 A99B 3340 LDA #NL
9EF9 204E9E 3350 JSR PTRPTB
9EFC 3360 CHKFO2 = *
9EFC AD019E 3370 LDA LPLIN
9EFF C901 3380 CMP #01
9F01 D0F4 3390 BNE CHKFO1
9F03 4C629F 3400 JMP TTYXT
          3410 ;
9F06 3420 CHKBEL = *
9F06 C907 3430 CMP #BEL
9F08 D00D 3440 BNE CHKCHR
9FOA 20679F 3450 JSR SEROUT
9F0D A90F 3460 LDA #15
9F0F 8D039E 3470 STA WTCT
9F12 4C629F 3480 JMP TTYXT
          3490 ;
9F15 3500 SNDSPC = *
9F15 A920 3510 LDA #'
9F17 3520 CHKCHR = *
9F17 297F 3530 AND #*7F
9F19 D8 3540 CLD
9F1A C920 3550 CMP #'
9F1C 90F7 3560 BCC SNDSPC
9F1E D017 3570 BNE CHKC1
9F20 EE079E 3580 INC SPCCT
9F23 AD009E 3590 LDA LPCOL
9F26 18 3600 CLC
9F27 6D079E 3610 ADC SPCCT
9F2A CD029E 3620 CMP RMARG
9F2D D033 3630 BNE TTYXT
9F2F A99B 3640 LDA #NL
9F31 204E9E 3650 JSR PTRPTB
9F34 4C629F 3660 JMP TTYXT
9F37 3670 CHKC1 = *

```

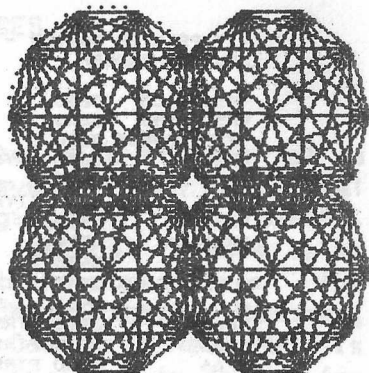

NEC 8023A-C ART
by Jack, WDBNG

```

9F37 C97E 3680 CMP #*7E
9F39 B0DA 3690 BCS SNDSPC
9F3B 48 3700 PHA
9F3C AD079E 3710 LDA SPCCT
9F3F FOOD 3720 BEQ CHKC3
9F41 3730 CHKC2 = *
9F41 A920 3740 LDA #'
9F43 20679F 3750 JSR SEROUT
9F46 EE009E 3760 INC LPCOL
9F49 CE079E 3770 DEC SPCCT
9F4C D0F3 3780 BNE CHKC2
9F4E 3790 CHKC3 = *
9F4E 68 3800 PLA
9F4F 20679F 3810 JSR SEROUT
9F52 EE009E 3820 INC LPCOL
9F55 AD029E 3830 LDA RMARG
9F58 CD009E 3840 CMP LPCOL

```

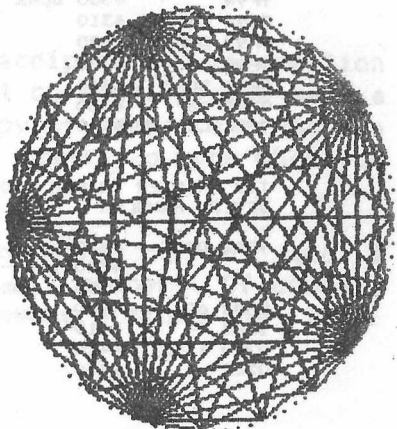

TTY PRINTER DRIVER - DOS VERSION
DEVICE HANDLER

```

9F5B D005 3850      BNE TTYXT
9F5D A99B 3860      LDA #NL
9F5F 204E9E 3870    JSR PTRPTB
9F62          3880    TTYXT = *
9F62 A001 3890      LDY #01
9F64          3900    TTYEXT = *
9F64 68 3910        PLA
9F65 AA 3920        TAX
          3930 ;
          3940 ; THE FOLLOWING ARE THE ENTRIES
          3950 ; WHICH ARE UNDEFINED
9F66          3960    PTRGTB = * ; GET BYTE
9F66          3970    PTRSTA = * ; GET STATUS
9F66          3980    PTRSPC = * ; SPECIAL I/O
9F66 60 3990        RTS
          4000 ;
          4010 ; SERIALIZE BYTE TO:
          4020 ; 1 START BIT
          4030 ; 8 DATA BITS
          4040 ; 1-2 STOP BITS (2-110 BAUD ONLY)
9F67          4050    SEROUT = *
9F67 8D069E 4060    STA SERCHR
9F6A A000 4070      LDY #0
9F6C A900 4080    SER01 LDA #TSPACE
9F6E 99099E 4090    SER02 STA BITARY,Y
9F71 CB 4100      INY
9F72 C009 4110    CPY #09
9F74 F00A 4120    BEQ SER03
9F76 6E069E 4130    ROR SERCHR
9F79 90F1 4140    BCC SER01
9F7B A901 4150    LDA #TMARK
9F7D 4C6E9F 4160    JMP SER02
9F80          4170    SER03 = *
9F80 A000 4180      LDY #0
          4190 ;
          4200 ; START TIME CRITICAL
          4210 ; CYCLE COUNT INCLUDED IN DELAY
          4220 ; -----
9F82 B9099E 4230    SER05 LDA BITARY,Y ; 4
9F85 8D00D3 4240    STA PORTA ; 4
9F88 AD149E 4250    LDA XVAL ; 4
9F8B 8D049E 4260    STA XCT ; 4
9F8E          4270    DLO1 = *
9F8E AD159E 4280    LDA YVAL ; 4
9F91 8D059E 4290    STA YCT ; 4
9F94          4300    DLO2 = *
9F94 CE059E 4310    DEC YCT ; 6
9F97 D0FB 4320      BNE DLO2 ; 2 3
9F99 CE049E 4330    DEC XCT ; 6
9F9C D0F0 4340      BNE DLO1 ; 2 3
9F9E CB 4350        INY ; 2
9F9F CC169E 4360    CPY BITCT ; 4

```

TTY PRINTER DRIVER - DOS VERSION
DEVICE HANDLER

```

9FA2 D0DE 4370      BNE SER05 ; 3
          4380 ; -----
          4390 ; END TIME CRITICAL
9FA4 60 4400        RTS
9FA5          4410    #= RUNADR
02E0 179E 4420      .WORD RSTART
02E2          4430      .END

```

MEMBER SERVICES

DISKETTES W/SLEEVES

We are now able to obtain diskettes with sleeves at a low price. Previously, the sleeves were an additional cost due to the bulk-style packaging of the disks. These disks could be one of several brands as we receive only what is available at the moment from the supplier. These brands have been Wabash, Memorex, Scotch and Verbatim in the past. Cost from Net HQ is \$2.00 per diskette. Shipping is included in orders for 5 diskettes or more. If the order is for less than 5 diskettes, please enclose an extra \$1.00 to cover the postage. The profit (\$.40 less postage) goes into making "Ad Astra..." bigger and better!

DISKETTE STORAGE BOXES

We have on hand a small number of plain white boxes of the type that diskettes are usually purchased in. These boxes are available for \$.50 each. Send an 8 X 10" envelope with enough postage for your boxes. Each box weighs approx. 1 oz. We will investigate the possibility of printing the "Ad Astra..." logo on the boxes at a later date!

IMPORTANT!

It is VERY important that members who have moved or changed their address to contact Net HQ with the new information immediately.

Also, if you feel that the "subscription" information on your mailing label is not correct, please send a photocopy of your check or a copy of your confirmation letter (the letter that was sent to you when you registered with the net.)

I try very hard to keep all information current and I have 2 separate data bases for all members. Of course, it IS possible that I goofed somewhere along the line! Let me know if you think I did!

THANKS!

Jack, WD8BNG

NEW MEMBERS!!!

It was my intention to print a comprehensive list of all of our members in this issue because I predicted that our growth after the Christmas season would slow down considerably! Not so! The members presented here are NEM! These good folks have joined our ranks only in the last 60 days! In order to have a complete list of members, you will have to combine this list with those found in Vol. 1, issues 5 and 6!

In order for us to withstand the economic impact of such a large number of folks, of which about 98% receive "Ad Astra...", I have obtained a bulk-rate permit from the post office. It does make more work for myself since I must keep all of the mailings in order by zip code, add stickers to the bundles etc. Of course the trusty ATARI Computer helps out with the help of DATA PERFECT! I still maintain a separate mailing list (of my own design) as it gives me a second data base to make comparisons with to prevent the accidental "loss" of a member's file.

I have also added one other feature to the data base.... every member of the net has a membership number! If I don't forget to format the labels correctly, you will find YOUR MEMBERSHIP NUMBER to the right of your name and callsign. These numbers were not arbitrarily assigned... they are assigned in the order in which you contacted net HQ for registration as a member. Guess who got #0001???

NEW MEMBERS AS OF APRIL 9, 1983

Charles Grenell WA4WSS

Steve Zeier

Vernon Harrison N6AUO

Ron Mettler NB4GHU

Dave Parker

James L. Porter

Pete Clough ND4GPO

Dave Weeks KY4I

Jefferson King KA8JKV

Donal Duffey WB4A

Warren Howard Jr. WB7BNP

Dale McNulty

Eddie Sexton N8EMZ

Vic Parker G6IRB

Bob Scott N9BCN/4

Ron Walters W4LDE

Marty Schultz

Zvonimir Makovek dipl.ing. YU3HI

Joel Malman WA1GM

Brian Erickson K0UJU

Charles Bloomer N4GVR

Greg Haines NB4PRU

Dr. Donald Deye M.D.

Steve White WA3IAO

Jimmy Davis (SM)

Bob Marchese K1NOK

Edouard Cournoyer W4UM0
Ken Wolfe KA5LEB
Ray Lowy WA5PPD
Jerry Green N8DI
John Behnke (SNL)
Dr. Wolfgang Klein DL1SAU
Jim Robb W6OUL
Larry Clouse N8AAU
Mark Yuill WB7FAM
Marty Rigoulot KA1IRA
Bill Jones WJ4H
Lanny Vrooman KB3BV
Tom Arciero WA2OHD
Peggy Arciero WB2OHD
Jim Perdue KC8NG
Frank Treadwell K3LDE
Tony Fonteccio
Lee Castille
Karl E. Eby
Russ Brandt KE4KL
Don Peattie WB6TEE
Al Jacobs W3BHN
Chuck Volkland W6JNF
L.B. Sanders NB8CJW
LeRoy Caudill (SNL)
Bill Carlton K8BTA
Southland Electronics
Alan Lefcort WB3GPR
Gene Royer WA6PSA
Robert Werner
Ray Burbank N4CXX
Donald Haves ND9EFT
Tom Becker NB9TJD
Marc Campbell Jr. W8RBO
Norman Allen K9FAR
Rev. Phillip Williams KA5DNB
Mrs. J. Hogan
Robert Hildebrand Jr. K3UWJ
Carl Shepard WB2DXZ
Jan McLernon KD6LB
Steve Elek Jr. KB9GP

Howard Estes WB4GUD
Ken Kroth WB2VJB
James Keckley N8BNY
Jeff Davis N8ADX
Woody Griggs WA4NZO
'Doc' Doctor WA9QJQ
Nylen Braun WA0VEX
Charles Laye
Mike Trussell KA8ASN
Rick Segal KA8LCX
Tony Terranova
Dean French N6AJK
Ken Morgan
Tom Monahan W3NGM
Burt Grebin K2KLN
Larry Engelbert N4ECP
Karl Schmitz VE6BKY
David Gregory KJ6P
Daniel Gregory N6HEY
Hadley Stacey KE0F
Al Gordon N6ZI
Les Otto KC9BD
Ron Azarkiewicz WA9RHU
Jim Bennett WB4WRK
Agust Bjarnason TF 3 OM
Arthur Clark W6OHS
Cheryl Peters NK6W
Al Gudbaur WB9ZHQ
Ed Cope ND2AKK
Bob Main KB4CL
Rufus Brown WA4LLO
Sheldon Messon (SNL)
Robert Mastracci (SNL)
Wayne Kennedy (SNL)
Tony Barber (SNL)
Bruce Freistedt
Gene Lee WB4NUM
Tom Hall AK2B
Richard Lawrence N8DUM
John Kirby N3AAZ

CLASSIFIEDS

I am very interested in swapping software with any other net members. Please contact: Woody Griggs, WA4NZO, 5213 35th Avenue West, Bradenton, FL 33529

I would be interested in trading programs from my library. Please send your list to me and I will do likewise. DE Larry Clouse, N0AAU, 305 W. Benton, Windsor, Missouri 65360

FOR TRADE: Microtek 32K board and Newell industries FASTCHIP (MATH). **WANTED:** Two (2) ATARI CX-853 16K RAM modules. Contact: Jimmy Davis, P.O. Box 6342, Lawton, Oklahoma 73506.



ATARI MICROCOMPUTER NETWORK LIBRARY

TO OBTAIN A LISTING OF LIBRARY PROGRAMS:

Send your request WITH \$1.00 to cover wear and tear on the printer to the librarian.

TO OBTAIN SPECIFIC PROGRAMS FROM THE LIBRARY:

Send the media, tape or disk, to the librarian along with a self-addressed stamped envelope with enough postage to cover return of the media. Any donation to cover the use of the drives would, I'm sure, be appreciated. The address for the library is:

LIBRARIAN- ATARI MICRO-NET

John Adams, KC5FW
17106 Happy Hollow
San Antonio, Texas 78232

```

20 REM *****
20 REM ***PRECISION AUDIO GENERATOR***
30 REM XXX          BY          XXX
40 REM XXX          DAVID VOIT  XXX
50 REM XXX          XXX
60 REM XXX          WBS&TOU    XXX
70 REM *****
80 ? CHR$(125)
90 ? "          PRECISION AUDIO GENERATOR":?
100 ? "THIS PROGRAM WILL CREATE A PRECISION"
110 ? "AUDIO FREQUENCY FOR TESTING AND"
120 ? "ALIGNMENT PURPOSES. THE FREQUENCY IS"
130 ? "WITHIN .06% OF THE SPECIFIED AMOUNT"
140 ? "AND AUDIO OUTPUT MAY BE OBTAINED FROM"
150 ? "THE MONITOR JACK PIN-2 (+) AND 3 (GND)"
160 ? "THE FREQUENCY MAY BE CHANGED BY"
170 ? "PRESSING <F> AND THE VOLUME MAY BE"
180 ? "RAISED OR LOWERED BY PRESSING"
190 ? "<+> OR <-> KEYS. THE PIN LAYOUT OF"
200 ? "THE JACK IS:"?:?
210 ? "  AUDIO 3o      oi COMPOSITE"
220 ? "  OUTPUT          LUMINENCE"
230 ?
240 ? "COMPOSITE 5o      o COMPOSITE"
250 ? "                2"
260 ? "                o"
270 ? "                GROUND"
280 ? :GOSUB 440
290 ? "SELECT A VOLUME LEVEL BETWEEN 0 AND 15";
300 INPUT V:VOLUME=V+160
310 POKE 53763,VOLUME:FOR T=1 TO 99:NEXT T
320 IF PEEK(764)=6 THEN VOLUME=VOLUME+1
330 IF PEEK(764)=14 THEN VOLUME=VOLUME-1
340 IF PEEK(764)=56 THEN GOSUB 440
350 POKE 765,255
360 IF VOLUME>175 THEN VOLUME=175
370 POKE 752,1
380 IF VOLUME<160 THEN VOLUME=160
390 ? CHR$(125):POSITION 2,1
400 ? "FREQUENCY= ";1789790/(2X(NF+7));" HERTZ"
410 ? "VOLUME= ";VOLUME-160
420 GOTO 310
430 POKE 764,255
440 POKE 764,255
450 ? "WHAT IS THE FREQUENCY IN HZ.";
460 INPUT F
470 NF=(1789790/(2XF))-7:IF NF-INT(NF)>.5 THEN NF=INT(NF+1)
480 HB=INT(NF/256):LB=NF-HB*256
490 POKE 53768,120:POKE 53762,HB:POKE 53760,LB
500 RETURN

```

NOTES FROM THE NET!

From Bill Froude, HP1XWF

If you have made a great boo boo by giving two or more files on a disk the same name, all is not lost! In BASIC direct mode, execute POKE 3118,0 and rename one of the files on the disk. As soon as this is done, re-boot by turning the system off to prevent confusing the DOS.

Also, Bill reminds us that using POKE 1913,80 will turn off the verify during write operation to speed up the process of transferring disk files.

Our thanks to Jack Perron of ATARI for the wonderful write-up that he gave us in the spring 1983 issue of "The ATARI Connection". We have added new members to our roster because of the publicity that Jack, Earl, and Ted have given us in the magazine.

Our congratulations to member Scott Persson, WB0QPP, whose article on programming your ATARI 800 into a RTTY AFSK generator was published in the March 1983 issue of "BYTE" Magazine. Scott has developed a complete RTTY program on a ROM board for the ATARI system! All indications are that this RTTY program will support disk I/O and has many advanced features. We will publish a complete review of this program as soon as possible. Preliminary reports are that it will support almost any TU that you can connect to the ATARI system! Also, your callsign is individually burned into the ROM when you order the program, making it un-necessary to even load in the callsign for the CW ID! Please contact Scott at: 4719 Valley St., Omaha, Nebraska 68106.

Rumor has it that there will be yet another commercial ATARI-based magazine in the near future! Apparently the ATARI Computer system has become so popular that it rates as many as the Apple and one more major magazine than the TRS-80! Let's hope the trend continues!

Jim Stafford, AA8B, has been using the MONARCH DATA SYSTEMS BASIC COMPILER, "ABC" for the past few weeks. Jim says that this compiler works extremely well and really speeds program execution several hundred percent! One word of caution is that like many compilers it does not support floating-point math functions and any programs using these functions will need conversions made. Jim says that the program is very well documented and that it is well worth the price!

Member John Behnke, SWL, writes to inform us that a company known as SPARTAN SOFTWARE, 3417 Nobel Ave. N., Crystal, Minnesota 55422, has a modification to the '810 disk drive and support software known as "ARCHIVER" that will allow the same capabilities as the highly acclaimed "Happy 810 ENHANCEMENT". Price for this mod is claimed to be \$75 as opposed to the "HAPPY 810 ENHANCEMENT" which goes for about \$250! No other information is known at this time.

And yet ANOTHER keyboard for the '400! This one is from ATTO-SOFT, 832 E. Third St., Galesburg, IL 61401, (309) 343-4114. This unit, the KB-400, fits into the '400's keyboard area in a manner like the INHOME SOFTWARE B-KEY 400. (Notice a similarity in names?) The KB-400's keyboard sits about 1/2" higher than it's highly acclaimed predecessor, but has the advantage of having a layout the same as the original '400 so no re-learning of the layout is necessary. Price of the KB-400 is \$89.95 + \$3.50 P&H.

From Don Moon, N6FTR:

I recently received Bob Holsti's new RTTY/ASCII program and I'm favorably impressed. I have never seen more complete menu-driven instructions than this package contains. I do wish that the program supported output to the printer. Bob's new Address is: 113C Ash Dr., Eglin AFB, Florida 32542

From member Jimmy Davis (SWL): I read the article about wiring up a connector to the monitor jack on the ATARI 800. I'm not very handy with a soldering iron so I took the easy way out! I went to my local TV-Stereo dealer and found a 5-pin DIN to 4-RCA phono-plug adapter. The color-coding on the model that I found was as follows: Black- audio, White- composite video, Red- composite luminance and Yellow- chroma. I had been using my VCR's video input for testing!

ANTIC!

We are pleased to report that ANTIC Magazine has announced that they will be going monthly starting with the April 1983 issue! This is a great development for all of us and it is indicative of the amount of support that the ATARI system is gathering in the marketplace as well as the aftermarket!

From Dave WA7JSC

AUTOMATE and RS232 SUPPORT

I was very pleased to see the January 83 issue of "COMPUTE" had several articles for the ATARI 400/800. One of them was "Automate your ATARI" by J.T. Mrobel. It is a BASIC program that allows you to write your own AUTORUN.SYS file. If you want to make things easier for unskilled operators, you may have preselected program come up running without typing a single character. This program is often one where any program can be simply selected from a menu.

Another article in the same issue described a communications program (JTERM) useful for transferring data to or from bulletin boards, time-share systems, or other ATARI's. I wanted to combine these two programs on one disk where JTERM would come up running. In a matter of minutes I used AUTOMATE to build a special AUTORUN.SYS. Powering the computer down and back up produced JTERM running as expected. Then "GOTCHA".....

"ERROR 130-NONEXISTANT DEVICE"

This message is saying that JTERM was trying to open "R1" and that the RS232 handler had not been loaded. After reading all I could find about the ATARI AUTORUN.SYS I could find little more than it polls the peripheral units (if any) and loads the 1762-byte RS232 handler from the 850. The Automate version of AUTORUN.SYS replaces, but does not include, the ATARI version.

Since I had already done too much to come up empty the only remaining option was to "GUESS".

My procedure follows:

- 1) Create AUTORUN.SYS with AUTOMATE. (Automatically written to disk)
- 2) Rename AUTORUN.SYS to AUTORUN.NEW.
- 3) Duplicate ATARI's AUTORUN.SYS from the Master diskette.
- 4) Copy AUTORUN.NEW, AUTORUN.SYS/A This APPENDS the New to the original.

Much to my amazement this procedure worked. The RS232 handler was loaded and the Autoboot worked also..GREAT! But what if....the 850 is turned off when booting?

!!!AMAZING machine this ATARI!!!

The Autoboot portion still works.

I don't understand all I know about this subject so please don't write and ask embarassing questions.....BUT IT WORKS.....

AND IT STILL WON'T RUN

Have you spent hours typing and days checking a program from a magazine only to decide there must be an error in the magazine? Sometimes there ARE errors in a printed program but not nearly as many as we make entering it. I ALWAYS have to do quite a bit of editing.

There are known BUGS in the ATARI screen editor that cause it to crash and hang the machine. Save your program every 10 to 15 minutes. Apparently there are other BUGS or at least TRAPS that allow characters to exist in a BASIC program that do not show in a listing.

When I can't find any errors in a new program but it still won't run I always do the following:

- 1)LIST the program to disk.
- 2)Clear memory with NEM command.
- 3)ENTER program from disk.
- 4)SAVE program
- 5)RUN program

In many cases the program will now run.

WRITE ENABLE NOTCH TOOL & GUIDE

Many homemade tools have been suggested for cutting the write enable notch in your single sided diskettes. You may have a readymade tool and not know it. Two snips from a Nibbling Tool and the new notch is identical to the original.

I then made a notch guide by cutting the corner from a heavy envelope and cutting the guide notch in it. Now I can quickly position the guide and SNIP-SNIP: PERFECT EVERY TIME!

Although not as cheap as homemade, the \$9.95 Nibbling Tool cuts diskettes AND 18 gauge aluminum.

from DAVE WA7JSC

USE A COMMON CASSETTE RECORDER FOR ATARI DATA!

A1, WA2NSM, has forwarded this schematic with the permission of Paul Trudeau who developed this system for attaching a standard audio tape recorder to the ATARI 400/800/1200XL system. According to A1, it works just fine on user-written tapes in BASIC, but difficulties may be experienced with machine-language tapes or commercially available tapes. CAVEAT USER!

Also, there is no provision for motor control, so you will have to cue the drive manually.

PARTS LIST

R1, R2	600 ohm 1/4 watt
R3	1350 ohm (1K+350)
R4, R7, R8, R9	100K ohm
R5	2670 ohm (2.2K+470)
R6, R13	2200 ohm
R10, R12	1000 ohm
R11	1 meg. ohm
R14	100 ohm
C1	1uf
C2, C8	10uf
C3, C5	.047uf
C4, C9	.001uf
C6, C7	.1uf
U1	LM 565
U2	LM 1458
D1	1N914
Q1	2N2222
B1, B2	9V transistor battery

Pins used on ATARI serial port:

Pin 4	Ground
Pin 3	Read line from tape
Pin 5	Write line to tape

Direct connection to the mic-input on the recorder from pin 5 of the serial port should suffice for recording purposes.

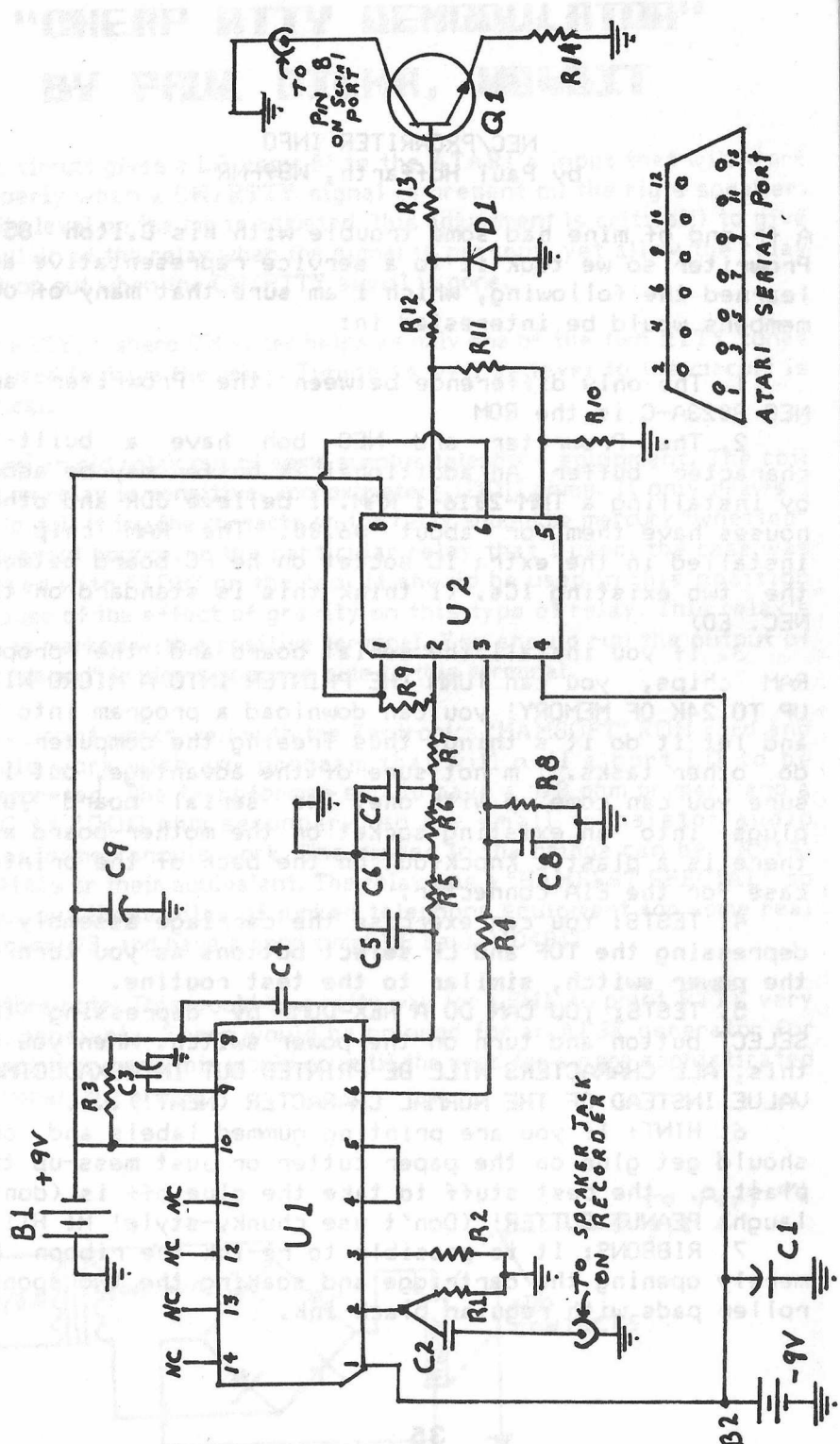

2	4	6	8	10	12
0	0	0	0	0	0
0	9	9	9	9	9
1	3	5	7	9	11

ATARI SERIAL PORT

NEC/PROWRITER INFO
by Paul Hoffarth, WB9FNR

A friend of mine had some trouble with his C.itech 8510 Prowriter so we took it to a service representative and learned the following, which I am sure that many of our members would be interested in:

1. The only difference between the Prowriter and NEC 8023A-C is the ROM

2. The Prowriter and NEC both have a built-in character buffer. An additional 2K buffer may be added by installing a TMM-2016-1 RAM. I believe JDR and other houses have them for about \$6.00. The RAM chip is installed in the extra IC socket on the PC board between the two existing ICs. (I think this is standard on the NEC. ED)

3. If you install the serial board and the proper RAM chips, you can **TURN THE PRINTER INTO A MICRO WITH UP TO 24K OF MEMORY!** you can download a program into it and let it do its thing, thus freeing the computer to do other tasks. I'm not sure of the advantage, but I'm sure you can come up with one. The serial board just plugs into an existing socket on the mother board and there is a plastic knock-out on the back of the printer case for the EIA connector.

4. TESTS: You can exercise the carriage assembly by depressing the TOF and LF select buttons as you turn on the power switch, similar to the test routine.

5. TESTS: **YOU CAN DO A HEX-DUMP** by depressing the SELECT button and turn on the power switch. When you do this, **ALL CHARACTERS WILL BE PRINTED OUT IN HEXADECIMAL VALUE INSTEAD OF THE NORMAL CHARACTER (NEAT!)....**

6. HINT: If you are printing gummed labels and one should get glue on the paper cutter or just mess-up the plastic, the best stuff to take the glue off is (don't laugh) **PEANUT BUTTER!** (Don't use chunky-style! HI HI)

7. RIBBONS: It is possible to re-ink the ribbon by merely opening the cartridge and soaking the two spongy roller pads with regular black ink.

"CHEAP RTTY DEMODULATOR"

BY PAUL GILKA, WD4BIT

This circuit gives a LO (logic 0) to the ATARI's input that will work properly when a CW/RTTY signal is present on the rig's speaker. Audio level on the rig is adjusted (this adjustment is critical!) to give a pull-in of the relay when the signal is present, yet allow the relay to drop out when the CW/RTTY signal is gone.

For RTTY, a sharp CW filter helps as only one of the two RTTY tones are used to drive the relay. Tuning as well as level to the circuit is critical.

I used an old relay out of some surplus telephone equipment. The coil in this relay is sensitive, approximately 1000 ohms. It only draws 5 ma to pull it in. The contacts on the relay should be mercury "whetted" to prevent bounce. In the particular relay that I used, the case was marked with "TOP" on the top. It should be used in this position because of the effect of gravity on this type of relay. This relay's coil is marked with a positive terminal. You should run the output of the "demod" bridge's positive side to this terminal.

This circuit works well with the Kantronics "HAMSOFT" ROM card and would work with any program that will pull a port LO to be interpreted. The transformer should have a 4/8 ohm primary and a 500 to 2000 ohm secondary, so any small transistor audio transformer should work. The diodes in the bridge can be 1N914, 1N4148s or their equivalent. The relay was a "HAMFEST SPECIAL" so check out those piles of junked telephone equipment for some real bargains! 73, and have a good time! DE Paul, WD4BIT

Editors note: This would be a nifty way for a SWL to print RTTY very inexpensively. There would be no need for an AFSK generator for transmitting and this would do until the need for a more sophisticated terminal unit arose.

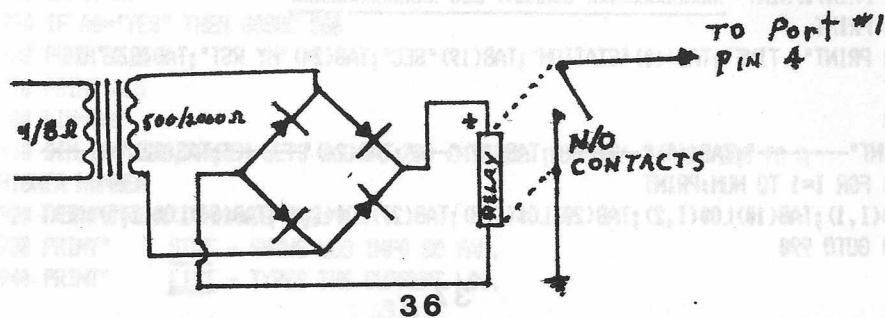

ATARI MICROSOFT BASIC CONTACT LOG PROGRAM by Randy Agee, WB4BZX

```

100 REM THIS PROGRAM IS IN MICROSOFT          BASIC
110 REM IT WILL NOT RUN WITH STANDARD      ATARI BASIC
120 REM
130 REM UNDERLINED WORDS ARE ENTERED      IN INVERSE VIDEO (ATARI
KEY)
140 REM
150 REM REVISION 18 MARCH 29, 1983
160 REM THIS VERSION HAS AUTO TIME
170 REM
180 REM XXXXXXXXXXXXXXXXXXXXXXXXXXXXXXXX
190 REM ) SYMBOLS IN LINE 1360 ARE          (ESC) + [(CTRL) + 2]
200 REM THE ABOVE BEEPS THE ATARI          INTERNAL SPEAKER.
210 REMXXXXXXXXXXXXXXXXXXXXXXXXXXXXX
220 REM
230 REM
240 CLS
250 PRINT:PRINT:PRINT
260 PRINT"XXXXXXXXXXXXXXXXXXXXXXXXXXXXX"
270 PRINT"%   Amateur Radio Contest Logger   %"
280 PRINT"%                                       %"
290 PRINT"%   For ATARI Computer Systems   %"
300 PRINT"XXXXXXXXXXXXXXXXXXXXXXXXXXXXX"
310 PRINT:PRINT:PRINT"  WRITTEN IN ATARI MICROSOFT BASIC
320 PRINT:PRINT"  FROM TRS-80 ORIGINAL BY K4LKQ
330 PRINT:PRINT"  EXTENSIVELY MODIFIED BY RANDY AGEE
340 PRINT
350 PRINT "                WB4BZX
360 FOR X= 1 TO 7000:NEXT
370 GOTO 650
380 REM XXXXXXXXXXXXXXXXXXXXXXXXXXXXXXXX
390 REM SUBROUTINES FOLLOW WITH THE          EXCEPTION OF PRINTER
OUTPUT.
400 REM XXXXXXXXXXXXXXXXXXXXXXXXXXXXXXXX
410 REM
420 PRINT:PRINT; NUM;" HAVE BEEN WORKED SO FAR":GOTO 990
430 PRINT:PRINT" XXXXXXXXXX CURRENT LOG XXXXXXXXXXXXX
440 PRINT
450 PRINT"  TIME";TAB(10)"STATION";TAB(19)"SEC";TAB(24)"MY RST";TAB(32)"HIS
RST
460
PRINT"-----";TAB(10)"-----";TAB(19)"-----";TAB(24)"-----";TAB(32)"-----
470 FOR I=1 TO NUM:PRINT
LO$(I,1);TAB(10)LO$(I,2);TAB(20)LO$(I,3);TAB(27)LO$(I,4);TAB(34)LO$(I,5):NEXT
480 GOTO 990

```

```

490 G=LEN(CA$)
500 FOR I= 1 TO NUM
510 FOR D=1 TO 6
520 IF MID$(LOG$(I,2),F,6)=CA$ THEN PRINT LOG$(I,2)
530 NEXT D
540 IF I=NUM THEN 1000
550 NEXT I
560 GOTO 520
570 PRINT:PRINT"CURRENT TIME IS ";TIME$:PRINT:GOTO 1000
580 ON ERROR GOTO 610
590 CLOSE #7:OPEN #7,"P:"
600 RETURN
610 CLS:PRINT:PRINT"YOUR PRINTER AND/OR 850 ARE NOT
620 PRINT"ON LINE. EITHER CORRECT THE PROBLEM
630 PRINT"OR ENTER NO
640 GOTO 820
650 CLS:PRINT:PRINT"WE NEED TO SET THE COMPUTER'S          INTERNAL CLOCK"
660 REM
670 REM XXXXXXXXXXXXXXXXXXXXXXXXXXXXXXXX
680 REM END SUBROUTINE MODULE - MAIN          PROGRAM FOLLOWS.
690 REM XXXXXXXXXXXXXXXXXXXXXXXXXXXXXXXX
700 REM
710 PRINT:PRINT"TIME MUST BE ENTERED IN 24 HOUR          FORMAT WITH
LEADING ZEROS WHERE          NECESSARY.":PRINT
720 PRINT :INPUT"ENTER CURRENT HOUR: ";HR
730 HR=INT(HR):IF HR<0 OR HR>23 THEN 720
740 T=HR*60*60*60
750 PRINT:INPUT"ENTER CURRENT MINUTE: ";MI
760 MIN=INT(MIN):IF MIN<0 OR MIN>59 THEN 750
770 T=T+MIN*60*60
780 PRINT:INPUT"ENTER CURRENT SECOND: ";SEC
790 SEC=INT(SEC):IF SEC<0 OR SEC>59 THEN 780
800 T=T+SEC*60:TIME=T
810 CLS
820 PRINT:PRINT"DO YOU HAVE A PRINTER ATTACHED TO"
830 PRINT"THE COMPUTER AND BOTH THE COMPUTER"
840 PRINT"AND 850 MODULE TURNED ON?"
850 PRINT"ENTER YES OR NO"
860 INPUT A$
870 IF A$="YES" THEN GOSUB 580
880 POKE 82,0
890 PRINT:CLS
900 LIM=200
910 DIM LOG$(200,5):REM SETS LOG TO 200 ENTRIES. YOU MAY CHANGE 200 TO A
HIGHER NUMBER
920 PRINT:PRINT"COMMANDS ARE:"
930 PRINT"          STAT - SHOWS LOG INFO SO FAR.
940 PRINT"          LIST - TYPES THE CURRENT LOG.

```

```

950 PRINT" TIME - PRINTS CURRENT 24 HOUR
960 PRINT" TIME TO THE SCREEN.
970 IF A$="YES" THEN PRINT" LPTR - SENDS LOG TO PRINTER
980 IF A$="YES" THEN PRINT" (PRINTER & 850 MUST BE ONLINE)
990 PRINT:PRINT
1000 INPUT"ENTER CALL OR COMMAND....";CA$
1010 CLS
1020 IF CA$="STAT" THEN 420
1030 IF CA$="LIST" THEN 430
1040 IF CA$="TIME" THEN 570
1050 IF CA$="LPTR" THEN 1470
1060 IF LEN(CA$)<4 THEN GOTO 990
1070 PTR=0
1080 IF CA$=LO$(PTR,2) THEN GOTO 1350
1090 PTR=PTR+1
1100 IF PTR<=NUM THEN GOTO 1080
1110 PRINT:PRINT:PRINT" XX OK TO WORK STATION ";CA$;" XX
1120 PRINT
1130 HRST$="" :MRST$=""
1140 INPUT"HIS RST ";HRST$
1150 IF LEN (HRST$)=0 THEN HRST$="599"
1160 IF HRST$="." THEN GOTO 1240
1170 INPUT "MY RST ";MRST$
1180 IF LEN(MRST$)=0 THEN MRST$="599"
1190 IF MRST$="." THEN GOTO 1240
1200 INPUT "SECTION ";SEC$
1210 IF SEC$="." THEN GOTO 1240
1240 NUM=PTR
1250 IF NUM= LIM THEN PRINT"LOG IS FILLED XXXXXXXX":GOTO 990
1260 LO$(NUM,1)=TIME$
1270 LO$(NUM,2)=CA$
1280 LO$(NUM,3)=SEC$
1290 LO$(NUM,4)=MRST$
1300 LO$(NUM,5)=HRST$
1310 PRINT
1320 GOTO 990
1330 STOP
1340 STOP
1350 PRINT:PRINT " XX YOU'VE WORKED "CA$" ALREADY XX
1360 PRINT""))))"
1370 FOR X=1 TO 1500:NEXT
1380 PRINT :PRINT :PRINT
1390 PRINT :GOTO 990
1400 FOR I=1 TO 5:PRINT LO$(PRT,1):NEXT
1410 PRINT:GOTO 990
1420 REM

```



```

1430 REM XXXXXXXXXXXXXXXXXXXXXXXXXXXXXXXX
1440 REM PRINTER SUBROUTINE FOLLOWS.
1450 REM XXXXXXXXXXXXXXXXXXXXXXXXXXXXXXXX
1460 REM
1470 ON ERROR GOTO 1540
1480 CLOSE #7:OPEN #7,"P:"
1490 PRINT #7:PRINT #7,"          XXXXXXX CURRENT LOG XXXXXXXXXXXXXXX
1500 PRINT#7
1510 PRINT #7,"TIME";TAB(10)"STATION";TAB(19)"SEC";TAB(24)"MY
RST";TAB(32)"HIS RST
1520 PRINT #7,"-----";TAB(10)"-----";TAB(19)"----";TAB(25)"--
---";TAB(32)"--- ---
1530 FOR I=1 TO NUM:PRINT #7,
LO$(I,1);TAB(10)LO$(I,2);TAB(20)LO$(I,3);TAB(27)LO$(I,4);TAB(34)LO$(I,5):NEXT
1540 GOTO 990
1550 STOP
1560 CLS: PRINT:PRINT:PRINT "YOUR PRINTER IS NOT ON LINE OR A
1570 PRINT "A CABLE IS LOOSE. CHECK YOUR
1580 PRINT "SWITCHES AND CABLES AND TRY AGAIN."
1590 FOR X=1 TO 3000:NEXT
1600 CLOSE #7
1610 GOTO 820
1620 STOP

```

STOPPING AC-SURGES
 by Jorge Gutierrez
 KA40TU

Faster than a speeding bullet a transient can zip down the power lines into your ATARI computer or peripherals and scramble hours of work.

One way to avoid the problem of power-line surge is to use a Surge Stopper, a device that squashes transient power-line variations before they get a chance to scramble the computer's RAM (Random Access Memory).

But first, do you really need one? The answer is YES. Depending on the device that caused it, a transient surge on a 117-volt residential power line can range to over 400 volts, and spikes as high as 1000 volts are not uncommon. Example: when your air conditioner or refrigerator kick on.

The actual protection is provided by a varistor. It provides a conductive path across the power line for transients that exceed the "breakover" rating - in this case, 130 volts RMS. This actually shorts the spikes to ground preventing them from being felt inside your computer.

CONTINUED ON PAGE 45

TEST DRIVING THE NEW ATARI 1200XL by stace, KEOF

I have just finished a three day test drive of the new ATARI 1200XL and was pleasantly surprised! Contrary to the many negative reports, it is my opinion that the 1200XL is a very good machine with several interesting and useful new features.

To put things in perspective, you must accept that all reviews (this one especially) are subjective, and reflect the reviewer's opinions and biases.

When Dave Ebert of Ebert's Personal Computers, Inc. called me and asked if I wanted to take a new 1200XL home for the weekend and try it out, I jumped at the chance. I was curious if it was as bad as several people were claiming, or was there more to it than just a pretty face. Well, I found enough to get pretty excited, and after 22 years of computers, it is pretty hard to excite me!

The first thing that you notice about the machine is the appearance, the styling is very pleasing without being gaudy. Second, the apparent absence of the rat's nest of cables that I am used to with the 800s and 400s. Finally, you notice that the access hatch bulge is missing, giving a pleasing low profile.

After standing and admiring the machine for a while, I sat down to use it.

The keyboard has been rearranged slightly with the game keys (OPTION, SELECT, START), SYSTEM RESET, BREAK and INVERSE VIDEO (ATARI KEY) on the top row above the normal keyboard. There are also five new programmable function keys labeled F1 thru F4 and HELP. There are also two programmable LEDs labeled L1 and L2. If you are using the screen editor F1 thru F4 will provide several useful functions listed below:

- F1 - Cursor up
- F2 - Cursor down
- F3 - Cursor left
- F4 - Cursor right

<shift> F1 - Cursor to top left
<shift> F2 - Cursor to bottom right
<shift> F3 - Cursor to bottom left

<ctrl> F1 - Disable/Enable keyboard
<ctrl> F2 - Turn the display off/on
<ctrl> F3 - Keyboard click off/on
<ctrl> F4 - European character set off/on

The cursor control keys eliminate the need to use the <ctrl> arrow combination.

You don't have to listen to the key clicks now if you don't want to.

The display control feature is particularly useful if you have programs which have extensive computation, the 1200XL (also 400/800) runs approximately 36% faster when the display is turned off.

Disabling the keyboard can be useful if you leave the computer unattended and don't want the kids or cats pressing random keys.

Now for the really good stuff. the 1200XL has 64K of RAM, 14K of ROM and 2K of hardware registers for a total of 80K. Most of you are aware that the 6502 microprocessor will only address 64K. The 1200XL uses a technique called "bank switching" which allows different parts of memory to have the same addresses (the 400 and 800 use the same technique in the cartridge address space).

Memory locations \$0000 thru \$7FFF is RAM, \$8000-\$BFFF is either RAM or cartridge ROM, depending on whether or not you have a cartridge installed (bank switching again).

Memory locations \$D000-\$CFFF and \$D800-\$FFFF can be defined as either RAM or ROM, depending on the value of the hardware register at location \$D301. If bit 0 is set to 0 then RAM is referenced.

But be careful, the resident operating system, character generator tables, interrupt handlers, etc are located in the ROM. If you indiscriminately change the bank select bit your screen will turn white (RAM doesn't contain a character generator table, and your machine will lock up (RAM doesn't normally contain an operating system)).

With proper planning and a little software, you now have the ability to install your own operating system without changing the OS board (SUPERMON maybe?). I would expect to see several different OSs available from third party software houses and maybe even ATARI. I'll suggest an immediate use a little later.

The function keys can be read by opening the keyboard (device "K:") or by peeking location 764 (decimal). Each has a unique value. The only problem I had was with the <ctrl> forms, the OS got them before I could. Eight new keys will probably satisfy most, and with more time and information somebody will figure out the others. I did not have time to figure out the HELP key.

The LEDs are controlled by bits 2 and 3 of the hardware register at location \$D301 (54017 decimal). Bit 2 controls L1 and bit 3 controls L2. Setting the control bit to 0 turns on the LED, and a 1 will turn it off.

The 1200XL also has a set of built-in diagnostics available. If you power up the 1200XL without a disk or cartridge, the system displays the word ATARI in a rolling rainbow of colors (color test?). Pressing HELP takes you to the self-diagnostic menu with choices for a RAM test, Audio-visual test (graphics and sound), keyboard test, or all tests (continually cycles thru all three tests).

Ed Fason and I were adventurous and opened the 1200XL to explore the circuit design and construction. While I don't claim to be an expert on such matters, I was impressed by the neatness of the component layout and board construction. All major ICs are socketed, not soldered (Easy to fix or replace with custom chips). The unit I had used EPROMs for the resident operating system and math package, but I would expect to see ROMs in later versions.

You hardware hackers may be disappointed in the single board construction until you notice all of the free space on the board and free space under the covers. Additional memory expansion will require new design approaches since there is not a separate memory board, but it shouldn't be too difficult.

Since I'm an amateur radio operator, I was particularly interested in the RFI characteristics. I'm pleased to report that the 1200XL is just as good as the 400/800 models. I didn't notice any interference on my receiver (Drake R4B), and the 1200XL didn't miss a beat when I keyed the exciter to a 1000 watt amplifier (both within 6 inches of the computer). The receiver tests were run from 1.5 to 29.7 Mhz. and the transmitter

tests on 3.7 and 14.25 Mhz. using both phone and CW. By the way, the VSWR at 3.7 Mhz was 3.5:1- there was plenty of RF floating around!

As a wise man once said, everything has it's faults, and the 1200XL is no exception. Whether they are major or minor depends on how you use your machine. I consider most of them minor for my type of operation.

First, there is very limited documentation for the 1200XL at this time. The only documentation I had access to was a very brief and superficial owner's guide. The technical information presented here was the result of analysis and experimentation. ATARI should have provided more detailed information on the new features with the unit.

The 1200XL has only two joystick ports. No more 4-player "ASTEROIDS" or 6 to 8-player "SUPER BREAKOUT". It also eliminates the use of ports 3 and 4 as an additional parallel I/O port.

There is only one cartridge slot (on the side) so you will have difficulty in using "MONKEY WRENCH" (in cartridge form). Also, several third-party software companies have deviated slightly from ATARI's cartridge dimensions (which should be considered a de-facto standard) and their cartridges won't fit the 1200XL without a little surgery.

The 1200XL operating system is a total re-write, and any software which doesn't use the supported vectors into the system probably will not work. Unfortunately, several commercial packages won't work with the 1200XL. Neither "TEXTWIZARD" nor "LETTER PERFECT" would work (I have heard that ATARI's word processor doesn't either). The rest of the software that I tested did work fine ("PROGRAM TEXT EDITOR", "MACRO-ASSEMBLER", "VISICALC", "PREPPIE", "PACIFIC COAST HIGHWAY", "STAR RAIDERS", etc.).

If the problems are OS incompatibility, then why doesn't someone copy the 800's OS to disk, load it into the 1200XL's RAM in the OS address space. I'll bet that a lot of software will then work. Besides, that would be a fun project!

Another area of incompatibility, but not really a fault, is that there appears to be a slight timing difference between the 1200XL and 400/800 models. I suspect that this is due to the improved DMA protocol between ANTIC and the 6502B. The effect is that timing loops may use less time. This could be a problem for disk programs which use multiple-sectoring, and use timing loops to locate the proper sector. 44

Finally, the price seems a little high, \$899 suggested list, \$799 at some stores. While the price is sure to come down, it will discourage some buyers as long as the '800 is priced at \$500.

Well, that's it for now. I will try to provide some more information next time. I would like to express my appreciation to Dave Ebert at Ebert Personal Computers, Inc. for providing the 1200XL for this review.

73, Stace, KE0F

Editor's note: We thank Stace for sharing his expertise in providing the first real "in depth" evaluation of the 1200XL. Stace has been a professional programmer for over 2 decades and is now involved with hardware interfacing for the ATARI system.

CONTINUED FROM PAGE 40

You may buy these units which range anywhere from \$30 to \$70 depending on their power rating and other features. The following is a unit that can be built by anyone for about \$10 to \$15. I built one and have been using it for the last six months.

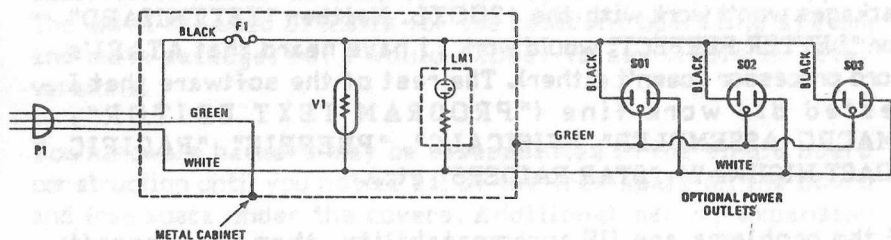

NOTE: ALL POWER CONNECTORS MUST BE U-GROUND TYPE.

The following is a parts list which can be purchased at any electronics parts house:

- V1 GE-MOV Varistor, type V130PA20C
- LM1 117-volt neon lamp assembly
- F1 3AG fuse, 10-15 amperes (whatever is necessary - do not exceed the rating of the power cable).
- P1 U-ground AC plug
- S01/2/3 U-ground AC outlets (however many you want).
- Misc. Fuseholder, Cabinet etc.

PLAYER-MISSILE DESIGN UTILITY

by Matt Wald, KADGE

This program will allow the user to design player-missile graphics characters by using the joystick in a manner similar to the character-editors available in commercial packages. When you have finished a design, just push the <START> key and the finished design will be have it's decimal values for each line displayed. The <SELECT> key will then display the actual player-missile design in each of the three widths available. If while you are making the design, you wish to start over, all that you have to do is hit the <OPTION> key to erase the design. Have fun!

```
5 GRAPHICS 0
6 SETCOLOR 2,0,0
7 SETCOLOR 1,15,15
8 ? "WAIT....."
10 ADD=PEEK(106)-24
20 BASE=ADD*256+1024
30 POKE 54279,ADD
40 FOR T=1 TO 255
50 POKE BASE+T,0
60 POKE BASE+255+T,0
70 POKE BASE+512+T,0
80 POKE BASE+768+T,0
85 POKE BASE-255+T,0
90 NEXT T
100 POKE 559,62
110 POKE 53277,3
160 POKE 53248,68
170 POKE 53249,76
180 POKE 53250,84
190 POKE 53251,92
195 POKE 53252,100
200 POKE 704,55
210 POKE 705,55
220 POKE 706,55
230 POKE 707,55
240 FOR T=40 TO 160:F=136
245 R=T/8:IF INT(R)*8=T THEN F=255
250 POKE BASE+T,F
260 POKE BASE+256+T,F
270 POKE BASE+512+T,F
280 POKE BASE+768+T,F
290 POKE BASE-256+T,2
300 NEXT T
```

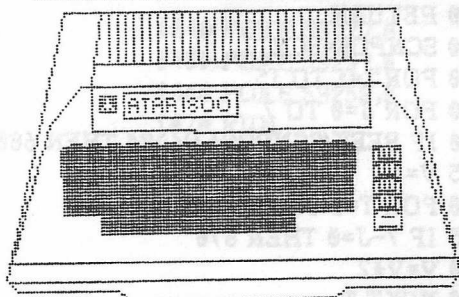
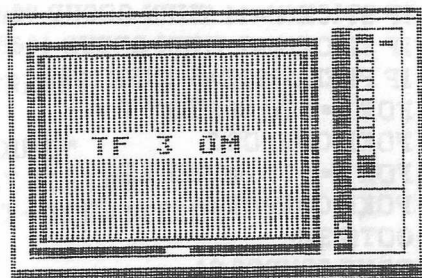

EPSON MX-80 ART
by Agust, TF30M

```

302 ? "3"
305 POSITION 5,18:? "USE OPTION TO CLEAR SCREEN":POSITION
5,19:? "USE START FOR PLAYER DUMP"
307 POSITION 5,20:? "TO DISPLAY PLAYER:"
308 POSITION 10,21:? "USE START--THEN SELECT"
310 DLIST=PEEK(560)+256*PEEK(561)
315 SCN=PEEK(DLIST+4)+256*PEEK(DLIST+5)+45
317 SCNPOS=SCN
320 HPOS=69:POKE 53253,HPOS
330 POKE BASE-256+43,14
337 CURPOS=BASE-256+43
340 IF STRIG(1)=0 THEN GOSUB 500
345 IF PEEK(53279)=3 THEN GOSUB 1100
350 IF PEEK(53279)=6 THEN GOTO 600
360 IF STICK(1)=14 THEN GOSUB 700
370 IF STICK(1)=13 THEN GOSUB 800
380 IF STICK(1)=11 THEN GOSUB 900
390 IF STICK(1)=7 THEN GOSUB 1000
391 IF PEEK(53279)=5 THEN 1200
392 FOR T=1 TO 50:NEXT T
395 POKE CURPOS,2
396 FOR T=1 TO 50:NEXT T
397 POKE CURPOS,14
400 GOTO 340
500 POKE SCNPOS,84
510 RETURN
600 SCNPOS=SCN
610 FOR I=1 TO 15
620 FOR J=0 TO 7
630 IF PEEK(SCNPOS+J)<>84 THEN 680
635 V=1
640 FOR T=1 TO 7-J
645 IF 7-J=0 THEN 670
650 V=V*2
660 NEXT T
670 VALUE=VALUE+V
680 NEXT J
685 POKE 1536+I,VALUE
690 POSITION 25,I:? VALUE:VALUE=0
695 SCNPOS=SCNPOS+40:NEXT I
696 POKE CURPOS,0:GOTO 310
700 IF SCNPOS<SCN+40 THEN RETURN
705 POKE CURPOS,2
710 CURPOS=CURPOS-8
720 POKE CURPOS,14
730 SCNPOS=SCNPOS-40
740 RETURN
800 IF SCNPOS>SCN+560 THEN RETURN
805 POKE CURPOS,2

```

810 CURPOS=CURPOS+8
 820 POKE CURPOS,14
 830 SCNPOS=SCNPOS+40
 840 RETURN
 900 IF HPOS<70 THEN RETURN
 910 HPOS=HPOS-4
 920 POKE 53253,HPOS
 930 SCNPOS=SCNPOS-1
 940 RETURN
 1000 IF HPOS>93 THEN RETURN
 1010 HPOS=HPOS+4
 1020 POKE 53253,HPOS
 1030 SCNPOS=SCNPOS+1
 1040 RETURN
 1100 ? "}"
 1110 POSITION 5,18
 1120 ? "USE OPTION TO CLEAR SCREEN"
 1125 POSITION 5,19
 1130 ? "USE START FOR PLAYER DUMP"
 1135 POSITION 5,20: ? "TO DISPLAY PLAYER:"
 1136 POSITION 10,21: ? "USE START--THEN SELECT"
 1140 RETURN
 1200 ? "}"
 1210 POKE 53252,0
 1220 POKE 53253,0
 1230 POKE 53248,0
 1240 POKE 53249,0
 1250 POKE 53250,0
 1260 POKE 53251,0
 1270 FOR T=1 TO 255
 1280 POKE BASE+T,0
 1290 POKE BASE+T+255,0
 1295 POKE BASE+512+T,0
 1300 NEXT T
 1310 POKE 53248,90
 1320 POKE 53249,110
 1330 POKE 53257,1
 1340 POKE 53250,140
 1350 POKE 53258,3
 1360 FOR T=1 TO 15
 1370 POKE BASE+125+T,PEEK(1536+T)
 1380 POKE BASE+256+125+T,PEEK(1536+T)
 1390 POKE BASE+512+125+T,PEEK(1536+T)
 1400 NEXT T
 1410 POSITION 5,18: ? "PLAYER IS SHOWN IN 3 WIDTHS"
 1420 POSITION 5,19: ? "PRESS START TO REDRAW PLAYER"
 1430 IF PEEK(53279)<>6 THEN 1430

Two bits, four bits, six bits,
 a byte;
 Tune to seventy-two thirty-five,
 and see the light!
 by Don Page, WD4HPL

1440 POKE 53277,0
 1450 POKE 53257,0
 1460 POKE 53258,0
 1470 RUN

MEMBER POLL

One of the members thought it would be interesting to find out how many of our members are "into" languages other than standard ATARI BASIC. We thought that this would be a fun thing to do and perhaps a poll would show the level of interest that our members have on a variety of subjects. I urge you all to spend 20 cents to respond to this questionnaire. Perhaps the folks at ATARI or a third-party will be able to use this information to good advantage!

Please check all sections that pertain to you and your household.

Do you own more than one ATARI computer?

YES NO

Do you own another brand of computer in addition to the ATARI?

YES NO

Which model ATARI computer(s) do you own?

400 800 1200XL My First Computer

Do you use a disk drive?

YES NO

If you use a disk drive, please indicate the model.

ATARI 810 ATARI 815 PERCOM DD PERCOM SD

MICRO MAINFRAME RANA Other_____

Please indicate the memory presently installed in your ATARI computer(s).

8K 16K 24K 32K 40K 48K 64K 128K 390K

Other_____

What is your favorite program of all time?_____

What percentage of "on-line" time do you devote your computer to?

Personal development _____%

Entertainment _____%

Research _____%

Data Management _____%

Retail Sales _____%

Learning Programming _____%

Word Processing _____%

Business Planning _____%

Graphic Development _____%

Amateur Radio _____%

Which programming languages do you use?

ATARI BASIC MICROSOFT BASIC OSS BASIC A+ PASCAL

FORTRAN

C FORTH LOGO PILOT Other(s)_____

Do you use any enhancements to the basic operating system on your ATARI? (BIT-3 80-column board, Monkey-Wrench, enhanced OS board, etc.)

YES NO If YES, specify_____

HERE IS YOUR CHANCE! What comments would you like Net HQ to pass along to ATARI? Please use additional space on a photocopy of this form if needed. Also, don't forget that you can use this space for positive comment as well as constructive criticism.

Is there any message that you would like to pass along to the industry about your desires for new products for your ATARI system? Please indicate the products that you would like to see.

Many thanks for your participation in this survey! We will probably do this once every year just to keep the industry informed. DE Jack, WD8BNG

PARTS FOR THE ATARI
from Mike Felack, WA3WOM

If you would like a chance to purchase replacement parts for your ATARI 400/800/1200XL, the following information should be of great benefit:

FLIGHT SYSTEMS HEADQUARTERS
P.O. Box 25, Hempt Road
Mechanicsburg, PA 17055
(717) 697-0342

This company has complete stocks of ATARI replacement parts on hand AND they will sell them to individuals. Now, instead of begging the part from your local service center, you have access to everything you will need to service your computer yourself.

THE ATARI MICROCOMPUTER NETWORK

JACK MCKIRGAN II WD8BNG

4749 S.R. 207 N.E.

Washington C. H., Ohio 43160

First Class

BULK RATE
U.S. POSTAGE
PAID
Washington C.H., Ohio
Permit No. 19